

## Series 26 Low Water Cutoff – Standoff Mount

- ▶ Meets CSD1 Requirements
- ▶ Non Powered Contacts
- ▶ Time Delays Available
- ▶ LED Monitoring
- ▶ U.L. “Limit Control”
- ▶ AC Current Minimizes Electrolysis
- ▶ Optional Dirty Electrode Detection
- ▶ Snap-Thru Standoff Mounting
- ▶ Compact Size
- ▶ Power Outage Feature
- ▶ CSA Approved
- ▶ Test Feature

### Series 26 – General Purpose Control

Designed for boiler low-water cutoff protection. A snap-through standoff mounting device is available for Series 26 units. Optional Power Outage feature resets after nuisance outages. Optional reset button is used when device has been deactivated because of low water condition. Reset is functional only if water has returned to normal level. Built-in 3 second time delay is standard. Up to 90 seconds available for increasing and decreasing levels.

### Specifications

<b>Contact Design</b>	1 N.O. & 1 N.C. (1 form C)
<b>Contact Rating</b>	10 amp Resistive 1/3 hp at 120, 240 VAC
<b>Mode of Operation</b>	Direct
<b>Sensitivity</b>	0-100K ohm, factory set
<b>Primary Voltage</b>	120 VAC, 240 VAC <sup>1</sup> , 24 VAC, 208/240 VAC (+10%/-15%) 50/60 Hz
<b>Secondary Voltage</b>	12 VAC, 1.5 mA
<b>Temperature</b>	-40°F to 150°F
<b>Approvals<sup>1</sup></b>	U.L. 353, U.L. 508 File # MP1430, CSA
<b>Terminal Style</b>	Spade connection
<b>Options</b>	Time Delays, Power Outage, Retrofit Plate, Test Feature, Dirty Electrode Detection

Notes:  
1. 208/240 VAC is not U.L. recognized

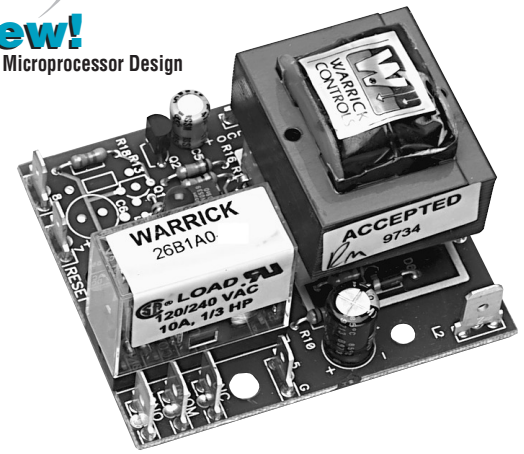

### Applications

- Low-Water Cutoff
- Point Level
- Valve Control
- Single-Level Service
- Alarms
- Pump Control

### Dimensions

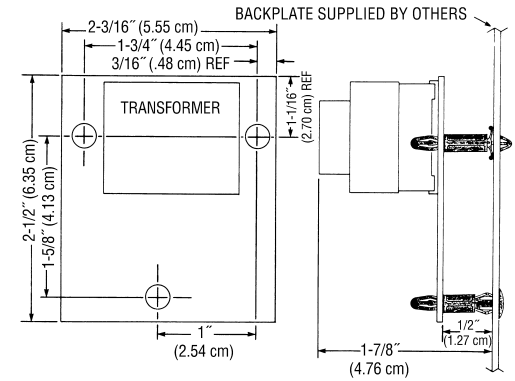

Socket Details and Option Availability are located on page D-36 and D-37.

Wiring

Series 26

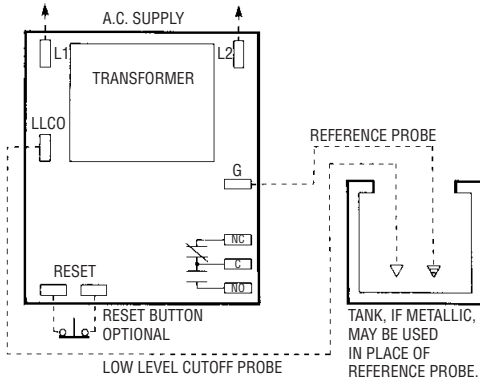

How to Order

Use the **Bold** characters from the chart below to construct a product code.

		<b>26</b>	<b>X</b>	<b>X</b>	<b>X</b>	<b>X</b>	<b>X</b>	<b>XX</b>	<b>XX</b>	<b>X</b>
1. Series										
	<b>26</b> General Purpose;									
2. Sensitivity										
	<b>A</b> 4.7K; <b>B</b> 10K; <b>C</b> 26K; <b>D</b> 50K; <b>E</b> 100K									
3. Supply Voltage										
	<b>1</b> 120 VAC; <b>2</b> 240 VAC; <b>3</b> 24 VAC; <b>8</b> 208/240 VAC									
4. Standoff Style <sup>1</sup>										
	<b>A</b> 1/16" Panel; <b>B</b> 1/8" Panel; <b>C</b> Screw mount; <b>D</b> Retrofit									
5. Enclosure										
	<b>0</b> None; <b>1</b> NEMA 1; <b>4</b> NEMA 4									
6. Option Package										
	See page D-36, Chart B for code letter									
7. Time Delay (decreasing level) Option										
	<b>03-90</b> seconds; <b>Blank</b> 3 seconds									
8. Time Delay (increasing level) Option										
	<b>00-90</b> seconds; <b>Blank</b> 0 seconds									
9. Dirty Probe Detection Option										
	<b>A</b> Yes <b>Blank</b> No									