



TYPE SP/P PRESSURE SAFETY PILOT

CONTROLS to 600 PSIG

- Self Contained
- Spring Operated
- Normally Closed
- Packless Construction
- Fluid, Gas & Vapor Applications
- Accurate Regulation Unaffected by Service Conditions
- Easy in-line Maintenance

TYPICAL CONFIGURATIONS

- PRESSURE REDUCINGTYPE EDSP/T
- PRESSURE REDUCINGTYPE E5DSP/T

TYPE SP/P PRESSURE SAFETY PILOT

APPLICATION DATA

- Where overpressure could cause personal injury or damage

RATINGS (Maximum Inlet Conditions)

Construction	Pressure PSIG (bar)	Temperature °F (°C)
Cast Bronze	250 (17.2) @	400 (204)
Cast Steel	600 (41.4) @	750 (400)

SPRING PRESSURE RANGES (PSIG)

5-13	31-65	121-175
13-30	66-120	

Canadian Registration # OC 0591.9C

TYPE SP/P PRESSURE SAFETY PILOT

SPECIFICATION

Pilot to be used to prevent an accidental rise in reducing valve pressure and not to be used as substitute for a safety relief valve. Valve is normally closed. Body to be cast steel rated 600 psig 750°F or bronze rated 300 psig 500°F. Valve must provide for easy in line maintenance and of packless construction. Operating pressure range to be determined by spring selection.

MATERIALS OF CONSTRUCTION

Body, Cast Bronze	ASTM B61-80 C92200
Body, Cast Steel	ASTM A216 GR. WCB
Stem.....	303 St. St. ASTM A582 COND A
Disc	440 St. St. ASTM A276 COND A
Seat	420 St. Stl ASTM A276 COND A
Gasket	Non-Asbestos
Diaphragm	301 St. Stl. MIL-5-5059C
Spring	Inconel

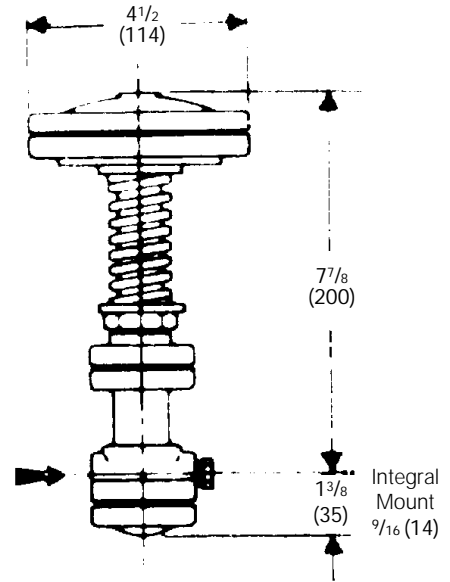

**TYPE SP/P PRESSURE
SAFETY PILOT
8 LBS. (3.6 KG)**

TYPE SP/P PRESSURE
SAFETY PILOT