

TYPE Q PILOT

TYPE Q BACK PRESSURE PILOT

CONTROLS 3 to 300 PSIG

- Self Contained
- Spring Operated
- Normally Open
- Packless Construction
- Four Adjustable Spring Ranges
- Fluid, Gas & Vapor Applications
- Loading Pressure Supplied by any Fluid
- Accurate Regulation Unaffected by Service Conditions
- Easy In-line Maintenance

OPTIONS

- Enclosed Spring Chamber
- Adjusting Handle
- High Pressure

MODELS

- **TYPE Q** for ± 1 psig accuracy controlling back pressures between 3 and 150 psig.
- **TYPE Q2** for ± 2 psig accuracy controlling back pressures between 100 and 300 psig.
- **TYPE Q73** air adjusted for ± 1 psig accuracy controlling back pressure at high retained pressures when available loading air is at low pressure. Delivery to loading pressure is 6-2/3 to 1 psig.

TYPICAL CONFIGURATIONS

- BACK PRESSURE CONTROL.....TYPE EQ
- BACK PRESSURE CONTROLTYPE E2Q
- BACK PRESSURE CONTROLTYPE E5Q

APPLICATION DATA

- Pump Bypass
- Maintain Upstream Pressure in Steam Distribution Systems
- Maintain Upstream Pressure in Liquid Distribution Systems

RATINGS (Maximum Inlet Conditions)

Construction	Pressure PSIG (bar)	Temperature °F (°C)
Cast Iron	250 (17.2) @	450 (232)
Cast Steel	600 (41.4) @	750 (400)

SPRING PRESSURE RANGES (PSIG)

TYPE Q	TYPE Q2
3-20	100-300
5-50	
10-100	
20-150	

Canadian Registration # OC 0591.9C

SIZING INFO
PAGE 122

TYPE Q BACK PRESSURE PILOT

SPECIFICATION

The Pilot shall be separate from the main valve and connected to it with a male union. The Pilot shall be normally closed design with packless construction. A strainer screen shall be built into the Pilot inlet. The Pilot shall be interchangeable on all sizes of main valves.

MATERIALS OF CONSTRUCTION

Body, Cast Iron	ASTM A126 CI B
Body, Cast Steel	ASTM A216 GR. WCB
Disc	440 St. St. ASTM A276-75 COND A
Seat	440 St. St. ASTM A276-75 COND A
Gasket	Non-Asbestos
Diaphragm	301 St. St. MIL-5-5059C
Spring	Steel

TYPE Q BACK PRESSURE PILOT

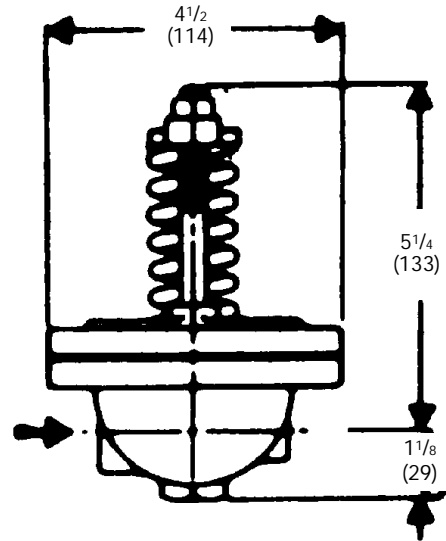

**TYPE Q PILOT
7 LBS.
(3.2 KG)**

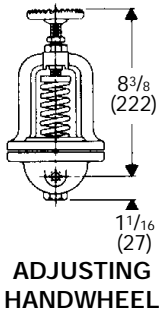

**ADJUSTING
HANDWHEEL**

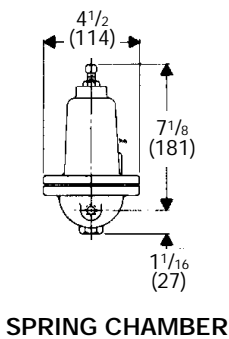

SPRING CHAMBER

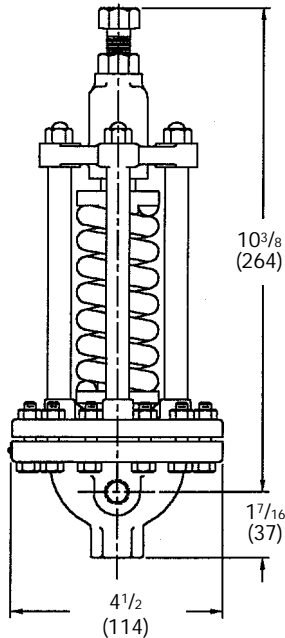

**TYPE Q2 PILOT
10 LBS.
(4.5 KG)**

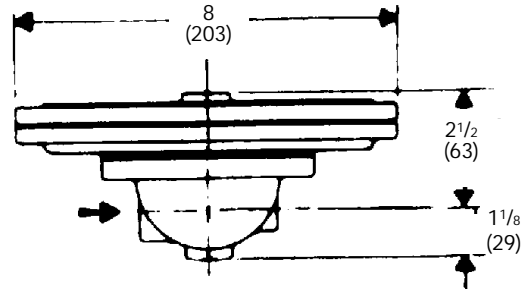

**TYPE Q73 PILOT
15 LBS.
(6.8 KG)**