

TYPE D34 WATER PRESSURE REDUCING VALVE

SIZES 1" – 6"
PRESSURES to 200 PSIG at 200°F

- Self-contained
- Closes Tight on Dead-end Shutoff
- Fast Acting for Rapid Changes in Flow
- Sediment Settles away from Control Ports when Installed Horizontally
- ANSI/FCI 70-2 Class VI Shutoff

**TYPE D34
WATER PRESSURE REDUCING VALVE**

APPLICATION DATA

- Dead-end water service where flow is intermittent and changes rapidly
- Flushometers
- Snap cocks

VALVE RATINGS

Valve Ends ASME/ANSI	Pressure PSIG (bar)	Temperature °F (°C)
-------------------------	------------------------	------------------------

CAST IRON

B16.4 Class 250 NPT	200 (13.8)	@ 200 (93)
B16.1 Class 125 Flanged	165 (11.4)	@ 200 (93)
B16.1 Class 250 Flanged	200 (13.8)	@ 200 (93)

SPRING RANGES (psi)

10-40	30-80
-------	-------

Canadian Registration # OC 0591.9C

Installation Tip: Add Uniflex Pipe Coupling for ease of maintenance
SEE PAGE 374

SIZING INFO
PAGE 108

RATED FLOW COEFFICIENTS (Cv)

	VALVE SIZE									
	1	1¼	1½	2	2½	3	4	5	6	
Cv	3.3	7.5	10.4	14.4	21.6	32	52	84	118	

TYPE D34 WATER PRESSURE REDUCING VALVE

SPECIFICATION

The Valve shall be adjustable, direct operated, packless, diaphragm actuated, balanced and single seated. The valve shall close tight on dead end shutoff and shall maintain a discharge pressure which will not vary more than 1 psig for each 10 psig inlet pressure variation. Delivery pressure variations from zero flow to rated flow shall not exceed 15% of the maximum spring pressure rating. The valve shall be suitable for 200°F service temperature.

Valve body shall be cast iron. Sizes 2-1/2" and larger shall have flanged ends. Trim shall be stainless steel. Valve shall be equipped with a reversible composition disc and diaphragms and discs shall be nitrile. All working parts shall be easily accessible without removal of valve from the line.

MATERIALS OF CONSTRUCTION

Body	Cast Iron ASTM 126 Cl. B
Stem	303 St. Stl. ASTM 582 Cond. A
Disc	304 St. Stl. ASTM 276 Cond. A
Seat	304 St. Stl. ASTM 276 Cond. A
Gasket	Non-asbestos
Diaphragm	Hycar
Spring	Steel

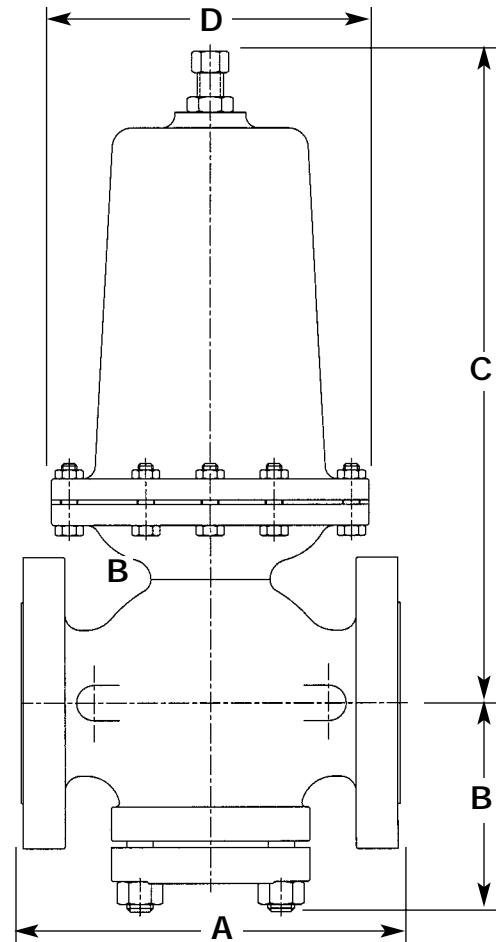

**TYPE D34
WATER PRESSURE REDUCING VALVE**

DIMENSIONS inches (mm) AND WEIGHTS pounds (kg)

SIZE	FACE TO FACE			OTHER DIMENSIONS			APPROX. WT.		
	A			B	C	D	APPROX. WT.		
	ANSI NPT	ANSI 125	ANSI 250				ANSI NPT	ANSI 125	ANSI 250
1 (25)	5 ³ / ₈ (136)	—	—	3 ³ / ₈ (86)	12 ¹ / ₈ (308)	5 ¹ / ₂ (140)	22 (10)	—	—
1 ¹ / ₄ (32)	6 ¹ / ₂ (165)	—	—	3 ⁵ / ₈ (92)	12 ¹ / ₂ (316)	5 ¹ / ₂ (140)	24 (11)	—	—
1 ¹ / ₂ (38)	7 ¹ / ₄ (184)	—	—	4 ¹ / ₄ (108)	13 ³ / ₈ (340)	6 (152)	34 (15)	—	—
2 (51)	7 ¹ / ₂ (191)	8 ¹ / ₂ (216)	9 (228)	4 ⁵ / ₈ (117)	14 ³ / ₄ (375)	6 ³ / ₄ (171)	44 (20)	51 (23)	57 (26)
2 ¹ / ₂ (64)	—	9 ³ / ₈ (238)	10 (254)	5 ¹ / ₂ (140)	18 ³ / ₄ (476)	8 (203)	—	78 (35)	89 (40)
3 (76)	—	10 (254)	10 ³ / ₄ (273)	6 (152)	21 ³ / ₄ (552)	9 (229)	—	108 (49)	128 (58)
4 (102)	—	11 ⁷ / ₈ (302)	12 ¹ / ₂ (318)	6 ⁵ / ₈ (168)	26 ⁵ / ₈ (676)	11 ¹ / ₄ (283)	—	198 (90)	225 (102)
5 (127)	—	13 ⁵ / ₈ (346)	14 ¹ / ₂ (268)	7 ⁵ / ₈ (194)	33 ¹ / ₈ (841)	14 ¹ / ₄ (362)	—	352 (160)	394 (252)
6 (152)	—	15 ¹ / ₈ (384)	16 (406)	9 ¹ / ₈ (232)	35 ⁷ / ₈ (911)	16 (406)	—	500 (227)	550 (250)