

TYPE E8 MAIN VALVE

TYPE E8 MAIN VALVE

AIR LOADED

SIZES $\frac{3}{8}$ " - 12"
PRESSURES to 250 PSIG at 406°F

- Normally Closed
- Single Seat
- Balanced Metal Diaphragms
- ANSI/FCI 70-2 Class IV Shutoff
- No Minimum Operating Differential Pressure
- Packless Construction
- No Pilot Needed
- Maximum 50 PSI Air Delivery Pressure
- Permits Remote Operation and Control
- Economical Alternative to Control Valve

APPLICATION DATA

- Pressure Regulating for Steam Distribution
- Regulating for Process Control (Temperature or Pressure)
- Maintain Back Pressure or Differential Pressure
- To use Air Load Pressure to Control Delivery Pressure
- Single Point or Multiple Use Applications
- Slow Start-up or Shutdown
- Use where "Dirty Steam" Conditions Exist

VALVE RATINGS

Valve Ends ASME/ANSI	Pressure PSIG (bar)	Temperature °F (°C)
-------------------------	------------------------	------------------------

CAST IRON

Class 250 NPT	250 (17.2)	@ 450 (232)
B16.1 Class 125 Flanged	125 (8.6)	@ 450 (232)
B16.1 Class 250 Flanged	250 (17.2)	@ 450 (232)

Canadian Registration # OC 0591.9C

OPTIONS *See page 42*

- Composition Disc
- Parabolic Disc
- Balanced Construction
- Dashpot
- Insulcap Insulating Jacket
- EZ Connections

TYPICAL CONFIGURATIONS

- PRESSURE REDUCINGTYPE E8 65A
- PRESSURE REDUCINGTYPE E8 A PANEL
- PRESSURE REDUCINGTYPE E8 B PANEL
- PRESSURE REDUCINGTYPE E8EPC
- TEMPERATURE CONTROLTYPE E8T61
- TEMPERATURE CONTROLTYPE E8EPC

Installation Tip: Add EZ Connections for ease of maintenance
SEE PAGE 42

SIZING INFO
PAGE 108

RATED FLOW COEFFICIENTS (Cv)

SEAT FACTOR	REGULATOR SIZE															
	$\frac{3}{8}$	$\frac{1}{2}$	$\frac{3}{4}$	1	1 $\frac{1}{4}$	1 $\frac{1}{2}$	2	2 $\frac{1}{2}$	3	4	5	6	8	10	12	
Full	1.5	2.8	5.4	8.8	14.1	19.8	31	44	74	109	169	248	444	706	1113	
Full 75 %	—	2.1	4.0	6.6	10.6	14.8	23.3	33	56	82	127	186	333	530	835	
Full 50 %	—	1.4	2.7	4.4	7.0	9.9	15.5	22	37	55	85	124	222	353	557	
Normal	.65	1.5	4.8	7.5	10.4	14.6	17.6	24	43	78	115	151	249	377	631	
Normal 75 %	—	—	—	—	—	—	—	18	33	59	87	114	187	283	474	
Normal 50 %	—	—	—	—	—	—	—	12	22	39	58	76	125	189	316	

TYPE E8 MAIN VALVE SPECIFICATION

The valve shall be air operated, single seated, metal diaphragm actuated, normally closed design. The valve will function quickly and shut tight on dead end service. Internal parts including seats, discs, stems and diaphragms shall be of stainless steel. There shall be no springs in the steam space and no stuffing box. The valve shall be easy to maintain with all parts accessible without removal from the line.

MATERIALS OF CONSTRUCTION

Body, Cast IronASTM A126 Cl. B
 Body, Cast BronzeASTM B61 UNS C92200
 Stem303 St. Stl. ASTM A582
 Disc 3/4 - 5"420 St. Stl. ASTM A743 CA-40
 Disc 6 - 12"304 St. Stl. ASTM A167/A240
 Seat 3/4 - 5"420 St. Stl. ASTM A743 CA-40
 Seat 6 - 12"316 St. Stl. ASTM A743-79 CF-8M
 GasketNon-asbestos
 DiaphragmStainless Steel MIL-S-5059C
 SpringSteel

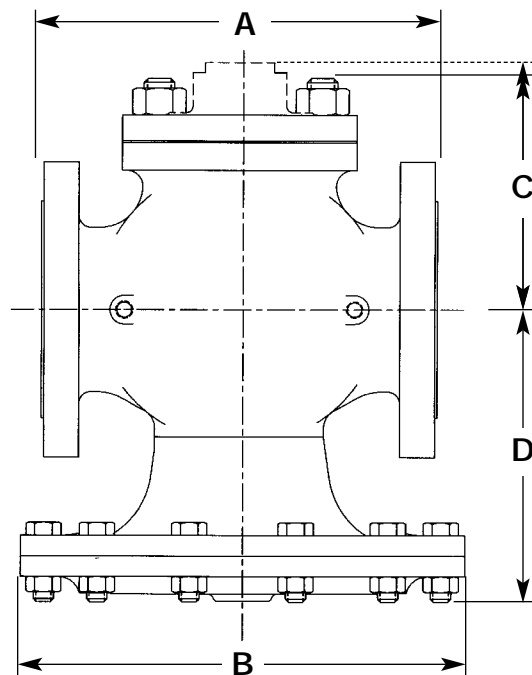

TYPE E MAIN VALVE

TYPE E8 MAIN VALVE

FITTINGS ON PAGE 46

DIMENSIONS inches (mm) AND WEIGHTS pounds (kg)

SIZE	FACE TO FACE DIMENSIONS					OTHER DIMENSIONS					APPROX. WT.					
	A					B	C		D	E	APPROX. WT.					
	ANSI NPT	ANSI 125,150	ANSI 250	ANSI 300	ANSI 600		ANSI 600				ANSI NPT	ANSI 125	ANSI 150	ANSI 250	ANSI 300	ANSI 600
3/8 (10)	4 3/8 (111)	—	—	—	—	5 7/8 (149)	2 3/4 (70)	—	5 1/4 (133)	7 3/8 (187)	14 (31)	—	—	—	—	—
1/2 (12)	4 3/8 (111)	—	—	—	6 (152)	5 7/8 (149)	2 3/4 (70)	2 3/4 (70)	5 1/4 (133)	7 3/8 (187)	14 (31)	—	—	—	—	20 (44)
3/4 (19)	4 3/8 (111)	—	—	—	6 3/8 (162)	6 1/2 (165)	2 7/8 (73)	3 7/8 (98)	5 1/2 (140)	7 7/8 (200)	18 (40)	—	—	—	—	28 (62)
1 (25)	5 3/8 (137)	5 1/2 (140)	6 (152)	6 1/2 (165)	6 1/2 (165)	7 (178)	3 5/8 (92)	4 1/4 (108)	6 1/4 (159)	8 7/8 (225)	23 (51)	24 (53)	26 (57)	27 (59)	31 (68)	32 (70)
1 1/4 (32)	6 1/2 (165)	6 3/4 (171)	7 1/4 (184)	7 7/8 (200)	7 7/8 (200)	7 7/8 (200)	4 1/8 (105)	4 5/8 (117)	6 1/2 (165)	9 1/8 (232)	33 (73)	36 (79)	37 (81)	40 (88)	41 (90)	45 (99)
1 1/2 (38)	7 1/4 (184)	6 7/8 (175)	7 3/8 (187)	8 (203)	8 (203)	8 3/4 (222)	4 3/8 (111)	5 1/8 (130)	7 1/8 (181)	9 3/4 (248)	43 (95)	45 (99)	47 (103)	51 (112)	55 (121)	58 (128)
2 (51)	7 1/2 (191)	8 1/2 (216)	9 (229)	10 1/4 (260)	10 1/4 (260)	9 7/8 (251)	5 1/4 (133)	5 3/4 (146)	7 5/8 (194)	11 1/4 (286)	62 (136)	67 (147)	73 (161)	72 (158)	78 (172)	83 (183)
2 1/2 (64)	—	9 3/8 (238)	10 (254)	11 1/4 (286)	11 1/4 (286)	10 7/8 (276)	5 3/4 (146)	7 7/8 (200)	8 3/8 (213)	12 1/8 (308)	—	82 (180)	95 (209)	100 (220)	100 (220)	130 (286)
3 (76)	—	10 (254)	10 3/4 (273)	12 1/4 (311)	12 1/4 (311)	11 3/4 (298)	6 5/8 (168)	9 1/8 (232)	9 1/4 (235)	14 5/8 (371)	—	110 (242)	125 (275)	130 (286)	140 (308)	175 (385)
4 (102)	—	11 7/8 (302)	12 1/2 (318)	12 1/2 (318)	14 1/2 (368)	14 3/4 (375)	7 5/8 (194)	10 5/8 (270)	11 7/8 (302)	18 1/4 (464)	—	200 (440)	210 (462)	235 (517)	230 (506)	310 (682)
5 (127)	—	13 5/8 (346)	14 1/2 (368)	14 1/2 (368)	16 1/2 (419)	16 7/8 (429)	8 1/2 (216)	12 1/2 (318)	12 1/2 (318)	20 1/8 (511)	—	280 (616)	295 (649)	315 (693)	310 (682)	490 (1078)
6 (152)	—	15 1/8 (384)	16 (406)	16 (406)	17 3/8 (441)	19 3/4 (502)	10 (254)	13 3/4 (349)	14 1/8 (359)	22 3/8 (568)	—	385 (847)	420 (924)	455 (1001)	470 (1034)	655 (1441)
8 (203)	—	19 (483)	20 (508)	20 (508)	21 5/8 (549)	22 1/2 (572)	11 1/2 (292)	15 5/8 (391)	17 1/4 (438)	27 3/4 (705)	—	657 (1445)	700 (1540)	735 (1617)	710 (1562)	1070 (2354)
10 (254)	—	23 5/8 (600)	25 (635)	25 (635)	—	28 (711)	13 3/4 (349)	—	23 3/8 (594)	36 1/4 (921)	—	1260 (2772)	1240 (2728)	1430 (3146)	1300 (2860)	—
12 (305)	—	26 1/2 (673)	28 (711)	28 (711)	—	33 (838)	15 7/8 (403)	—	25 1/4 (641)	41 1/2 (1054)	—	2070 (4554)	2060 (4532)	2145 (4719)	2140 (4708)	—