



DOCTOR SERIES MD 3-WAY CONTROL VALVE

SIZES 1/2" – 12"
ANSI CLASS 125/150, 250/300

APPLICATION DATA

- Process control systems for food, pulp and paper, chemical, petrochemical & other industries
- HVAC systems
- Feed water and fuel system controls in boiler rooms
- Packaged systems (OEM) such as heat exchangers, water purification systems & vaporizer, metal cleaning and plating
- Especially designed for mix or diverting of clean, dirty, viscous and corrosive liquids, gasses and steam

- **Rigid Port Guiding** dampens vibration and ensures proper seating.
- **High Capacity Body Designs** means valve body flow areas are 140% of normal valve, reducing velocities and pressure loss.
- **Balanced Plug Design** of DV provides gradual, stable transition.
- **316 SS Valve Plugs & Seat Rings** for corrosion resistance
- **Mixing or Diverting** to suit your application.
- **Live Loaded V ring Packing** is self adjusting.

MODELS

- M1 — Cast Iron Mix (MX)
- M2 — Cast Steel Mix (MX)
- M3 — Stainless Steel Mix (MX)
- M4 — Cast Iron Diverting (MX)
- M5 — Cast Steel Diverting (MX)
- M6 — Stainless Steel Diverting (MX)
- M7 — Cast Iron Diverting (DV)
- M8 — Cast Steel Diverting (DV)
- M9 — Stainless Steel Diverting (DV)

OPTIONS

- 40, 85, 145, 250 sq. in. Reverse and Direct Actuators
- Soft Seat
- Moore and PMV Accessories
- Alternate Packing for Severe Service
- Graphite or High Temperature Packing

APPLICABLE CODES

- ANSI B16.0 Face-To-Face Dimensions and ISA S75.03 Uniform Face-To-Face Dimensions for Flanged Globe Style Control Valves
- ANSI B16.37 Hydrotesting of Control Valves
- ISA S75.02 Control Valve Capacity Test Procedure

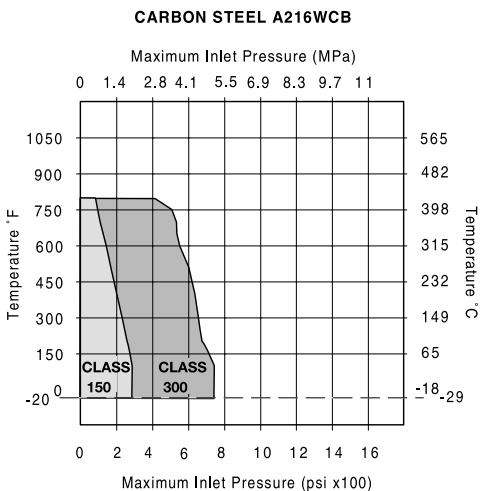
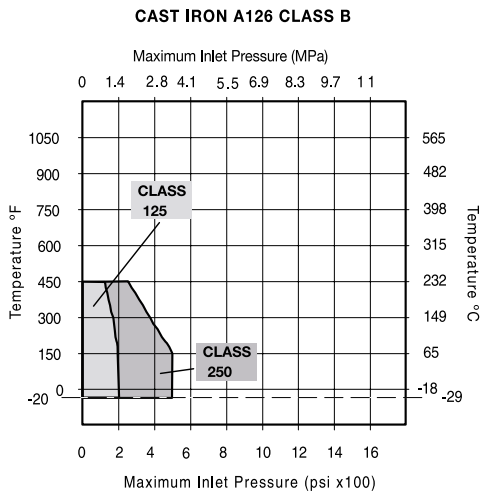

MAXIMUM RATED FLOW COEFFICIENTS* (Cv)

MODEL	VALVE SIZE											
	1/2	3/4	1	1 1/2	2	2 1/2	3	4	6	8	10	12
MX	5	7	12	28	50	70	116	158	352	475	739	1070
DV	5	7	12	28	52	76	108	160	365	475	795	1078

DOCTOR SERIES MD

3-WAY CONTROL VALVE

SPECIFICATION

All three way control valves shall be designed, built and tested in accordance with the latest revision of applicable industry standards. Valve body materials and end connections shall be as specified on the valve data sheets, in accordance with ANSI B16.34 and B16.5. Bonnets shall be through bolted, of the same material as the valve body. Stem packing shall be adjustable and suitable for the intended service. Asbestos or asbestos filled packings are prohibited. If graphite packing is selected or specified, use alternating rings of braided and die-cut anti-extrusion rings. Live-loaded PTFE V-ring packing shall be used to 450°F. Packing gland, clamp, studs and nuts shall be of 300 Series stainless steel. Rigid port guiding utilizing V-notch flow ports and balanced plug design on diverting service shall be used. Trim shall be of 316 Series corrosion resistant stainless steel. Valve Characteristic shall be modified linear or equal percent. Valve stems shall be 316 stainless steel with a minimum 16 RMS finish. Plug/stem assemblies shall be of a two piece threaded and pinned design. Actuators shall be of the spring and diaphragm type suitable for 60 psig continuous service. Actuators shall be capable of shutting off the valve without the use of line pressure assist. Actuator yokes shall be of cast iron unless otherwise specified and bolted or clamped to the valve bonnet. Locknut mounting is not preferred. Top mounted

handwheel manual overrides shall be provided where specified. Rim pull required to operate valve shall not exceed 40 pounds. Valves shall be sized to control within manufacturers published rangeability. Size valve to pass 110% of maximum stated flow. Valve generated noise shall not exceed 85 dBA when measured 3 feet downstream and 3 feet away from the pipe.

MATERIALS OF CONSTRUCTION

BodyIron ASTM A-126 Class B
 ASTM A-216 Steel Gr.WCB
 ASTM A-351 Gr.CF8M
 Plug316 St. Stl. ASTM A351 Grade CF8M
 Seat Rings ...316 St. Stl. ASTM A351 Grade CF8M
 Stem316 Stainless Steel
 Spring (V-Ring Packing)316 Stainless Steel
 Packing SetBTG, TC, LG or Environmental
 Packing Follower316 Stainless Steel
 Packing FlangeCadmium Plated Steel
 GasketNitrile Rubber Bonded, PTFE or Grafoil®

DOCTOR SERIES MD
3-WAY VALVE

CODE SELECTION CHART

Model	Orifice	Size	Connections	Trim	Packing-	Actuator	Spring	Positioner	Posit. Set	Accessories -	Inlet Pressure								
M	1	T	J	2	1	1	4	2	C	1	A	A	0	1	0	1	1	2	5
1	2	3	4	5	6	7	8	9	10	11	12	13	14	15	16	17	18	19	20

Model - Position 1 & 2 M1 = Cast Iron M2 = Cast Steel M3 = SS Mix (MX) M4 = CI Div (MX) M5 = CS Div (MX) M6 = SS Div (MX) M7 = CI Div (DV) M8 = CS Div (DV) M9 = SS Div (DV)	Size - Position 4 C = ½ D = ¾ E = 1 F = 1¼ G = 1½ H = 2 J = 2½ K = 3 M = 4 P = 6 Q = 8 R = 10 T = 12	Trim - Position 6 1 = Metal Packing - Position 7 1 = V-ring 2 = Graphite 3 = Hi-Temp Actuator - Position 8 & 9 01 = None 40 = 40S Rev 41 = 40S Dir 42 = 85S Rev 43 = 85S Dir 44 = 145S Rev 45 = 145S Dir 46 = 250S Rev 47 = 250S Dir	Spring - Position 10 & 11 AA = None B1 = B1C B2 = B2C B6 = B6C C1 = C1E C2 = C2E C6 = C6E D1 = D1E D2 = D2E E1 = E1E E2 = E2E E3 = E3E F1 = F1F Positioner - Position 12 & 13 MI = Moore I/P MP = Moore P 4P = PMV P4 P 5I = PMV P5 I/P 5P = PMV P5 P	Positioner Set Position 14 & 15 01 = None 02 = 3-15/4-20 mA 03 = 3-9/4-12 mA 04 = 9-15/12-20 mA Accessories - Position 16 & 17 01 = None 02 = Limit Switch, Mechanical 03 = Limit Switch, Proximity Switch 04 = Feedback Potentiometer 1K 05 = Feedback 4-20mA Posit. Trans Inlet Pressure - Position 18, 19 & 20 _ _ _ _ = Actual Setting
---	---	---	--	--

DOCTOR DIMENSIONS

Dimensions of Actuators

fig 1	D I R E C T A C T I N G					
	inches (mm)	H	HH	W	WGT Lbs.(Kgs.)	
	MODEL					
	DL-40-D	19.5 (495)	32.7 (831)	10.1 (257)	37 (17)	
	DL-85-D	20.9 (531)	41.7 (833)	14.8 (375)	84 (38)	
	DL-145-D	29 (739)	49.8 (1044)	19.3 (489)	192 (87)	
	DL-250-D	31.3 (795)	54.3 (1158)	23.6 (600)	251 (114)	

fig 2	R E V E R S E A C T I N G					
	inches (mm)	H	HH*	W	WGT Lbs.(kgs.)	
	MODEL					
	DL-40-R	25.8 (655)	39.8 (1011)	10.1 (257)	54 (25)	
	DL-85-R	38.4 (975)	57.4 (1458)	14.8 (375)	125 (57)	
	DL-145-R	47.5 (1207)	66.5 (1689)	19.3 (489)	197 (89)	
	DL-250-R	57.8 (1468)	76.8 (1951)	23.6 (600)	331 (150)	

* See Fig. 2A

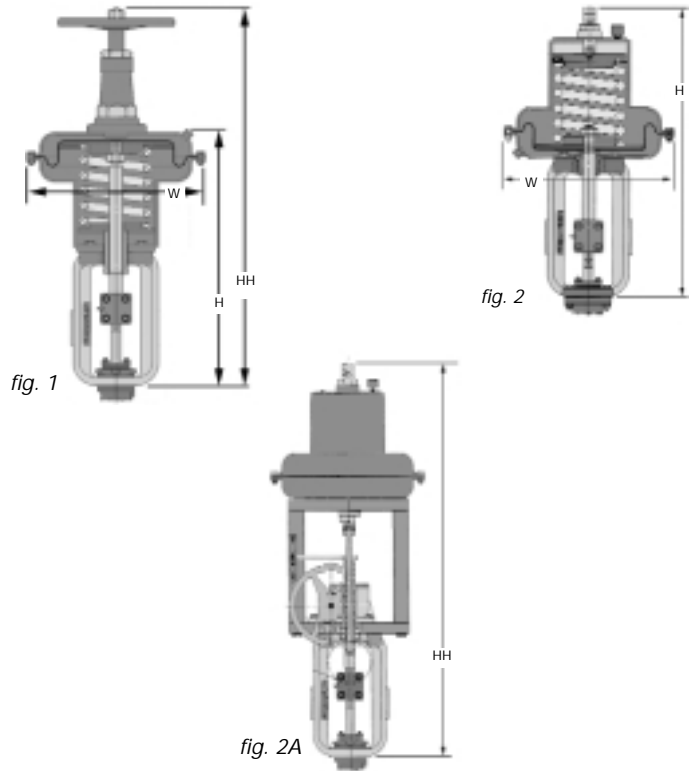

Dimensions of Bodies C Dimensions

Valve Size inches (mm)	Standard Bonnet					
	Yoke Code					
	C&E		F		H	
	Mixing	Diverting	Mixing	Diverting	Mixing	Diverting
.5 (15)	4.62 (117.3)	4.62 (117.3)	—	—	—	—
.75 (20)	4.62 (117.3)	4.62 (117.3)	—	—	—	—
1 (25)	5.44 (138.2)	5.44 (138.2)	—	—	—	—
1.5 (40)	6.25 (158.8)	6.25 (158.8)	7.38 (187.5)	7.38 (187.5)	—	—
2 (50)	6.88 (174.8)	6.88 (174.8)	8.00 (203.2)	8.00 (203.2)	—	—
2.5 (65)	7.66 (194.6)	7.66 (194.6)	8.75 (222.2)	8.75 (222.2)	9.88 (251.0)	9.88 (277.1)
3 (80)	7.31 (185.7)	8.72 (221.5)	8.44 (214.4)	9.84 (249.9)	9.50 (241.3)	10.91 (277.1)
4 (100)	8.94 (227.1)	9.88 (251.0)	10.06 (255.5)	11.00 (279.4)	11.19 (284.2)	12.12 (307.8)
6 (150)	—	—	11.81 (300.0)	14.31 (363.5)	12.94 (328.7)	15.44 (392.2)
8 (200)	—	—	—	—	15.00 (381.0)	17.19 (436.6)
10* (250)	—	—	—	—	17.0 (431.8)	19.19 (487.4)
12* (300)	—	—	—	—	18.38 (466.9)	21.88 (555.8)

*On Application
Note: All dimensions are subject to change without notice. Request certified drawings for use in preparing piping layouts. All dimensions given in Inch (millimeter)

See diagrams on facing page

Actuator Notes

- Size 40 uses "C" yoke only.
- Size 85 uses "E" yoke only.
- Size 145 uses "E" yoke only.
- Size 250 uses "E, F, H" yoke sizes.

DOCTOR DIMENSIONS

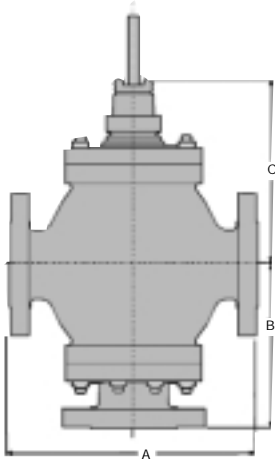

Valve Sizes
Diverting 0.5" - 1.5"
Mixing 0.5" - 12"

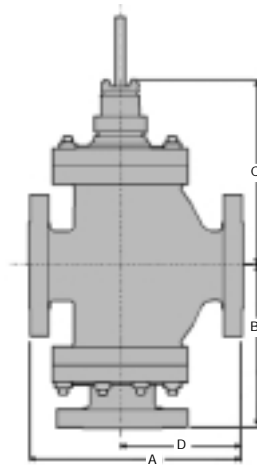

Valve Sizes
Diverting 2" - 12"

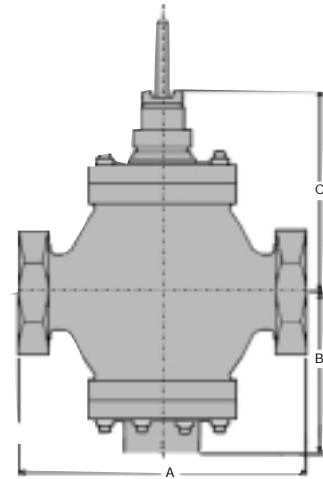

Valve Sizes
Diverting 0.5" - 2"
Mixing 0.5" - 2"

DOCTOR
DIMENSIONS

Dimensions of Bodies A, B & D Dimensions

DIMENSIONS IN INCHES				Shpg. Info. ¹		DIMENSIONS IN MILLIMETERS				Shpg. Info. ¹	
SIZE	A	B	D	WGT.	VOL.	SIZE	A	B	D	WGT.	VOL.
ANSI 125/150 Flanged - Mixing & Diverting											
.5	7.25	5.56	—	45 lb.	1 ft ³	15	184	141.2	—	20 kg	.03 m ³
.75	7.25	5.62	—	45 lb.	1 ft ³	20	184	142.7	—	20 kg	.03 m ³
1	7.25	6.19	—	61 lb.	1 ft ³	25	184	157.2	—	28 kg	.03 m ³
1.5	8.75	7.44	—	72 lb.	2 ft ³	40	222	189.0	—	33 kg	.06 m ³
2	10.00	7.81*	5.44	94 lb.	2 ft ³	50	254	198.4*	138	43 kg	.06 m ³
2.5	10.88	8.75*	—	105 lb.	3 ft ³	65	276	222.2*	—	48 kg	.08 m ³
3	11.75	8.19*	6.81	160 lb.	3 ft ³	80	298	208.0*	173	73 kg	.08 m ³
4	13.88	10.19*	8.12	193 lb.	5 ft ³	100	353	258.8*	206	88 kg	.14 m ³
6	17.75	12.12*	10.44	455 lb.	8 ft ³	150	451	307.8*	265	206 kg	.23 m ³
8	21.38	14.69*	12.69	635 lb.	13 ft ³	200	543	373.1*	322	288 kg	.37 m ³
10	26.00	17.50*	15.50	1050 lb.	21 ft ³	250	648	444.5*	394	476 kg	.59 m ³
12	29.75	19.81*	18.00	1690 lb.	30 ft ³	300	756	503.2*	457	767 kg	.85 m ³
ANSI 250/300 Flanged - Mixing & Diverting											
.5	7.5	5.69	—	45 lb.	1 ft ³	15	191	144.5	—	20 kg	.03 m ³
.75	7.62	5.75	—	45 lb.	1 ft ³	20	194	146.0	—	20 kg	.03 m ³
1	7.75	6.44	—	61 lb.	1 ft ³	25	197	163.6	—	28 kg	.03 m ³
1.5	9.25	7.69	—	72 lb.	2 ft ³	40	235	195.3	—	33 kg	.06 m ³
2	10.5	8.06*	5.69	94 lb.	2 ft ³	50	267	204.7*	267	43 kg	.06 m ³
2.5	11.5	9.06*	—	105 lb.	3 ft ³	65	292	230.1*	—	48 kg	.08 m ³
3	12.5	8.56*	7.19	160 lb.	4 ft ³	80	318	217.4*	318	73 kg	.11 m ³
4	19.5	10.50*	8.44	193 lb.	8 ft ³	100	368	266.7*	368	88 kg	.23 m ³
6	18.62	12.56*	10.88	455 lb.	10 ft ³	150	473	319.0*	473	206 kg	.28 m ³
8	22.38	15.19*	13.19	635 lb.	16 ft ³	200	569	385.8*	568	288 kg	.45 m ³
10	26.88	18.19*	16.19	1050 lb.	24 ft ³	250	682	462.0*	683	476 kg	.68 m ³
12	31.25	20.56*	18.75	1690 lb.	36 ft ³	300	794	522.2*	817	767 kg	1.02 m ³
ANSI 250 Threaded - Mixing & Diverting											
.5	5.69	3.62	—	45 lb.	1 ft ³	15	144.5	91.9	—	20 kg	.03 m ³
.75	5.69	3.62	—	45 lb.	1 ft ³	20	144.5	91.9	—	20 kg	.03 m ³
1	6.19	4.44	—	61 lb.	1 ft ³	25	157.2	112.8	—	28 kg	.03 m ³
1.5	7.75	5.30	—	72 lb.	2 ft ³	40	196.8	136.7	—	33 kg	.06 m ³
2	9.19	6.06	—	94 lb.	2 ft ³	50	233.4	153.9	—	43 kg	.06 m ³

NOTE: DIMENSIONS ARE SUBJECT TO CHANGE WITHOUT NOTICE. Request certified drawings for piping layout and construction purposes.

¹ Approximate weight and volume
* Mixing Service ONLY

DOCTOR PRINCIPLE OF OPERATION

The Three Way Globe Valve design has been successfully applied for over 50 years in chemical, refining, power, paper, and H.V.A.C. industries worldwide. They are designed for mixing or diverting of clean, dirty, viscous and corrosive liquids, high and low pressure steam, and clean, dirty and corrosive gases.

MIXING SERVICE (Type MX)

The inner valves in type MX seat inside the two seat rings (see illustration A). When these valves are used for mixing service, the forces developed by the two inlet flows oppose each other, creating little, if any, unbalance. Thus, the actuator can control the flow efficiently, with very little power lost in overcoming dynamic unbalance.

The Type MX valve is also used for diverting service, generally restricted to the smaller sizes (see illustration B).

DIVERTING SERVICE (Type DV)

In contrast to the MX control valve, the inner valve in the type DV seats outside the two seat rings (see illustration C). The flow enters between the two seats and the pressure tends to move the inner valve away from the seats, adding to the stability of operation. Therefore, the Type DV is preferred for diverting service in larger valve sizes and at higher pressure.

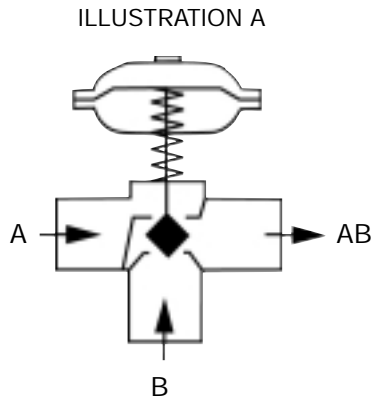

Type MX Inner Valve used for mixing service.

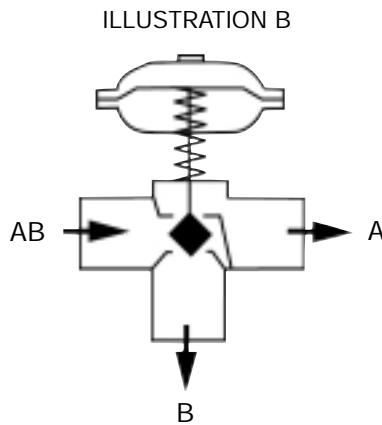

Type MX Inner Valve used for diverting service 1/2" - 2" sizes only.

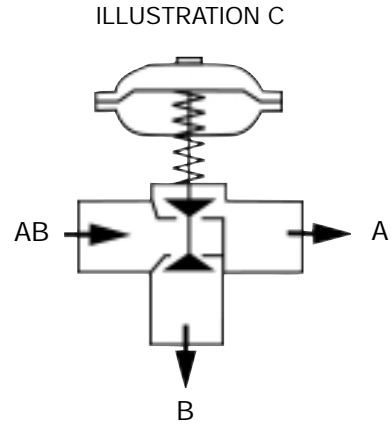

Type DV Inner Valve used for diverting service.

Note: When selecting a direct acting actuator, plug is up on air loss. When selecting a reverse acting actuator, plug is down on air loss.

DOCTOR SHUTOFF & CV TABLE

ACTUATOR SHUTOFF TABLE
(Direct & Reverse)

Valve Size	Actuator Code	Spring Number	20 psi air
			12 psi Span
1	40	B2	0 - 140
	40	B1	140 - 225
	42	C2	225 - 430
1-1/2	40	B1	0 - 65
	40	B6	65 - 105
	42	C1	105 - 200
	44	E2	200 - 220
	44	E1	220 - 445
2	42	C1	0 - 100
	42	C6	100 - 180
	44	E1	180 - 235
	46	E3	235 - 320
2-1/2	42	C1	0 - 50
	42	C6	50 - 90
	44	E1	90 - 110
	44	D2	110 - 200
3	42	C6	0 - 50
	44	D2	50 - 115
	46	E2	115 - 160
4	44	D1	0 - 75
	46	E1	75 - 115
6	46	F1	0 - 55

Consult Factory for 3/4" and 1/2" sizes.

Cv TABLE

Valve Size Inches (mm)	Mixing-Type MX	Diverting-Type DV
.5 (15)	5	5
.75 (20)	7	7
1 (25)	12	12
1.5 (40)	28	28
2 (50)	50	52
2.5 (65)	70	76
3 (80)	116	108
4 (100)	158	160
6 (150)	352	365
8 (200)	475	475
10 (250)	739	795
12 (300)	1070	1078

DOCTOR WATER CAPACITY TABLE

(Modified Equal Percent Contour Plug) (G.P.M.)

DOCTOR WATER CAPACITY TABLE

Pressure (PSI)		Valve Size and Type																		
		1/2	3/4	1	1.5	2		2.5		3		4		6		8		10		12
P1	P2					MX	DV	MX	DV	MX	DV	MX	DV	MX	DV	MX	DV	MX/DV	MX	DV
10	5	11	16	27	63	112	116	157	170	259	241	353	358	787	816	1062	1652	1778	2393	2410
	2	14	20	34	79	141	147	198	215	328	305	447	453	996	1032	1344	2090	2249	3026	3049
15	10	11	16	27	63	112	116	157	170	259	241	353	358	787	816	1062	1652	1778	2393	2410
	7	14	20	34	79	141	147	198	215	328	305	447	453	996	1032	1344	2090	2249	3026	3049
	3	17	24	42	97	173	180	242	263	402	374	547	554	1219	1264	1645	2560	2754	3707	3734
20	15	11	16	27	63	112	116	157	170	259	241	353	358	787	816	1062	1652	1778	2393	2410
	10	16	22	38	89	158	164	221	240	367	342	500	506	1113	1154	1502	2337	2514	3384	3409
	3	21	29	49	115	206	214	289	313	478	445	651	660	1451	1505	1958	3047	3278	4412	4445
30	25	11	16	27	63	112	116	157	170	259	241	353	358	787	816	1062	1652	1778	2393	2410
	20	16	22	38	89	158	164	221	240	367	342	500	506	1113	1154	1502	2337	2514	3384	3409
	5	25	35	60	140	250	260	350	380	580	540	790	800	1760	1825	2375	3695	3975	5350	5390
40	25	19	27	46	108	194	201	271	294	449	418	612	620	1363	1414	1840	2862	3079	4144	4175
	15	25	35	60	140	250	260	350	380	580	540	790	800	1760	1825	2375	3695	3975	5350	5390
	6	29	41	70	163	292	303	408	443	676	630	921	933	2052	2128	2770	4309	4636	6239	6286
50	35	19	27	46	108	194	201	271	294	449	418	612	620	1363	1414	1840	2862	3079	4144	4175
	30	22	31	54	125	224	233	313	340	519	483	707	716	1574	1632	2124	3305	3555	4785	4821
	25	25	35	60	140	250	260	350	380	580	540	790	800	1760	1825	2375	3695	3975	5350	5390
60	7	33	46	79	184	328	341	459	498	761	708	1036	1049	2308	2393	3115	4846	5213	7016	7069
	45	19	27	46	108	194	201	271	294	449	418	612	620	1363	1414	1840	2862	3079	4144	4175
	40	22	31	54	125	224	233	313	340	519	483	707	716	1574	1632	2124	3305	3555	4785	4821
75	25	30	41	71	166	296	308	414	450	686	639	935	947	2082	2159	2810	4372	4703	6330	6378
	9	36	50	86	200	357	371	500	543	828	771	1128	1143	2514	2607	3392	5278	5677	7641	7698
	55	22	31	54	125	224	233	313	340	519	483	707	716	1574	1632	2124	3305	3555	4785	4821
100	50	25	35	60	140	250	260	350	380	580	540	790	800	1760	1825	2375	3695	3975	5350	5390
	5	40	56	96	224	400	416	560	608	928	864	1264	1280	2816	2920	3800	5912	6360	8560	8624
	14	46	65	111	260	464	482	649	705	1076	1002	1465	1484	3264	3385	4405	6853	7373	9923	9997
125	100	25	35	60	140	250	260	350	380	580	540	790	800	1760	1825	2375	3695	3975	5350	5390
	50	43	61	104	242	433	450	606	658	1005	935	1368	1386	3048	3161	4114	6400	6885	9266	9336
	18	52	72	124	290	517	538	724	786	1200	1117	1634	1655	3641	3776	4913	7644	8224	11068	11151
150	125	25	35	60	140	250	260	350	380	580	540	790	800	1760	1825	2375	3695	3975	5350	5390
	75	43	61	104	242	433	450	606	658	1005	935	1368	1386	3048	3161	4114	6400	6885	9266	9336
	20	57	80	137	319	570	593	798	867	1323	1231	1801	1824	4013	4162	5416	8426	9064	12200	12291
175	150	25	35	60	140	250	260	350	380	580	540	790	800	1760	1825	2375	3695	3975	5350	5390
	100	43	61	104	242	433	450	606	658	1005	935	1368	1386	3048	3161	4114	6400	6885	9266	9336
	50	56	78	134	313	559	581	783	850	1297	1207	1766	1789	3935	4081	5311	8262	8888	11963	12052
200	24	61	86	147	344	614	639	860	934	1425	1327	1942	1966	4325	4485	5837	9081	9769	13148	13247
	150	35	49	85	198	354	368	495	537	820	764	1117	1131	2489	2581	3359	5226	5621	7566	7623
	100	50	70	120	280	500	520	700	760	1160	1080	1580	1600	3520	3650	4750	7390	7950	10700	10780
225	27	66	92	158	368	658	684	921	1000	1526	1421	2078	2104	4630	4801	6248	9720	10457	14074	14179
	175	35	49	85	198	354	368	495	537	820	764	1117	1131	2489	2581	3359	5226	5621	7566	7623
	100	56	78	134	313	559	581	783	850	1297	1207	1766	1789	3935	4081	5311	8262	8888	11963	12052
250	30	70	98	168	391	698	726	977	1061	1620	1508	2206	2234	4915	5097	6633	10320	11102	14942	15053
	200	35	49	85	198	354	368	495	537	820	764	1117	1131	2489	2581	3359	5226	5621	7566	7623
	175	43	61	104	242	433	450	606	658	1005	935	1368	1386	3048	3161	4114	6400	6885	9266	9336
300	100	61	86	147	343	612	637	857	931	1421	1323	1935	1960	4311	4470	5818	9051	9737	13105	13203
	34	73	103	176	412	735	764	1029	1117	1705	1587	2322	2352	5173	5364	6981	10861	11684	15726	15843
	250	35	49	85	198	354	368	495	537	820	764	1117	1131	2489	2581	3359	5226	5621	7566	7623
400	100	71	99	170	396	707	735	990	1075	1640	1527	2234	2263	4978	5162	6718	10451	11243	15132	15245
	40	81	113	193	451	806	838	1129	1225	1870	1741	2548	2580	5676	5885	7659	11916	12819	17253	17382
	350	35	49	85	198	354	368	495	537	820	764	1117	1131	2489	2581	3359	5226	5621	7566	7623
400	200	71	99	170	396	707	735	990	1075	1640	1527	2234	2263	4978	5162	6718	10451	11243	15132	15245
	50	94	131	224	524	935	973	1310	1422	2170	2020	2956	2993	6585	6829	8886	13825	14873	20018	20168

- It is recommended to keep valve outlet velocity below 30,000 ft./min.
- Capacities based on maximum Cv.



DOCTOR WATER CAPACITY TABLE

(Modified Equal Percent Contour Plug) (M3/Hr.)

Pressure (bar)		Valve Size and Type																									
		1/2		3/4		1		1.5		2		2.5		3		4		6		8		10		12			
P1	P2	MX	DV	MX	DV	MX	DV	MX	DV	MX	DV	MX	DV	MX	DV	MX	DV	MX	DV	MX/DV	MX	DV	MX	DV	MX	DV	
0.7	0.5	2	3	5	11	19	20	27	29	45	42	61	62	136	141	184	286	307	414	417							
	0.2	3	4	7	17	31	32	43	46	71	66	97	98	215	223	290	452	486	654	659							
1	0.7	2	3	6	13	24	25	33	36	55	51	75	76	167	173	225	350	377	507	511							
	0.5	3	4	7	17	31	32	43	46	71	66	97	98	215	223	290	452	486	654	659							
	.2	4	5	9	22	39	40	54	59	90	84	122	124	272	282	367	572	615	828	834							
1.5	1	3	4	7	17	31	32	43	46	71	66	97	98	215	223	290	452	486	654	659							
	0.7	4	5	9	22	39	40	54	59	90	84	122	124	272	282	367	572	615	828	834							
	.2	5	7	12	28	49	51	69	75	114	106	156	158	347	360	468	729	784	1055	1063							
2	1.5	3	4	7	17	31	32	43	46	71	66	97	98	215	223	290	452	486	654	659							
	1	4	6	10	24	43	45	61	66	100	93	137	138	304	316	411	639	687	925	932							
	.3	6	8	14	32	56	59	79	86	131	122	178	180	397	412	536	833	896	1206	1215							
3	2	4	6	10	24	43	45	61	66	100	93	137	138	304	316	411	639	687	925	932							
	1	6	9	15	34	61	64	86	93	142	132	193	196	430	446	581	904	972	1309	1318							
	.5	7	10	16	38	68	71	96	104	159	148	216	219	481	499	649	1010	1087	1463	1474							
3.5	3	3	4	7	17	31	32	43	46	71	66	97	98	215	223	290	452	486	654	659							
	2	5	7	13	30	53	55	74	80	123	114	167	169	373	387	503	783	842	1133	1142							
	1	7	10	16	38	68	71	96	104	159	148	216	219	481	499	649	1010	1087	1463	1474							
	.5	7	10	18	42	75	78	105	114	174	162	237	240	527	547	711	1107	1191	1603	1615							
4	3	4	6	10	24	43	45	61	66	100	93	137	138	304	316	411	639	687	925	932							
	2	6	9	15	34	61	64	86	93	142	132	193	196	430	446	581	904	972	1309	1318							
	1	7	10	18	42	75	78	105	114	174	162	237	240	527	547	711	1107	1191	1603	1615							
	.6	8	11	19	45	80	83	112	121	185	172	252	255	561	582	757	1178	1268	1706	1719							
5	4	4	6	10	24	43	45	61	66	100	93	137	138	304	316	411	639	687	925	932							
	3	6	9	15	34	61	64	86	93	142	132	193	196	430	446	581	904	972	1309	1318							
	2	7	10	18	42	75	78	105	114	174	162	237	240	527	547	711	1107	1191	1603	1615							
	.8	9	12	21	50	89	92	124	135	206	191	280	284	624	647	842	1310	1409	1896	1910							
6	5	4	6	10	24	43	45	61	66	100	93	137	138	304	316	411	639	687	925	932							
	3	7	10	18	42	75	78	105	114	174	162	237	240	527	547	711	1107	1191	1603	1615							
	1	10	14	23	54	97	101	135	147	224	209	306	309	681	706	919	1429	1537	2069	2085							
8	6	6	9	15	34	61	64	86	93	142	132	193	196	430	446	581	904	972	1309	1318							
	3	10	14	23	54	97	101	135	147	224	209	306	309	681	706	919	1429	1537	2069	2085							
	1.1	11	16	27	64	114	118	159	173	264	245	359	363	800	829	1079	1679	1806	2431	2449							
10	8	6	9	15	34	61	64	86	93	142	132	193	196	430	446	581	904	972	1309	1318							
	5	10	14	23	54	97	101	135	147	224	209	306	309	681	706	919	1429	1537	2069	2085							
	1.4	13	18	30	71	127	132	178	193	294	274	401	406	893	926	1205	1874	2016	2714	2734							
12	10	6	9	15	34	61	64	86	93	142	132	193	196	430	446	581	904	972	1309	1318							
	7	10	14	23	54	97	101	135	147	224	209	306	309	681	706	919	1429	1537	2069	2085							
	5	11	16	27	64	114	119	160	174	265	247	361	366	805	835	1087	1691	1819	2448	2466							
	1.7	14	19	33	78	139	144	194	211	322	300	439	444	977	1013	1318	2051	2206	2970	2992							
14	10	9	12	21	48	86	90	121	131	201	187	273	277	609	631	822	1278	1375	1851	1864							
	7	11	16	27	64	114	119	160	174	265	247	361	366	805	835	1087	1691	1819	2448	2466							
	2	15	21	36	84	150	156	210	228	347	324	473	479	1054	1093	1423	2214	2382	3205	3229							
15	12	7	10	18	42	75	78	105	114	174	162	237	240	527	547	711	1107	1191	1603	1615							
	7	12	17	29	68	122	127	171	186	284	264	386	391	861	893	1162	1808	1945	2617	2637							
	2	16	22	37	87	156	162	218	237	362	337	493	499	1098	1138	1481	2304	2479	3336	3361							
17	14	7	10	18	42	75	78	105	114	174	162	237	240	527	547	711	1107	1191	1603	1615							
	10	11	16	27	64	114	119	160	174	265	247	361	366	805	835	1087	1691	1819	2448	2466							
	5	15	21	36	84	150	156	210	228	347	324	473	479	1054	1093	1423	2214	2382	3205	3229							
	2.4	17	23	40	93	165	172	231	251	383	357	522	529	1163	1206	1570	2442	2627	3536	3562							
20	15	10	14	23	54	97	101	135	147	224	209	306	309	681	706	919	1429	1537	2069	2085							
	10	14	19	33	77	137	142	191	208	317	295	432	438	963	998	1299	2021	2174	2926	2948							
	2.7	18	25	43	101	180	187	252	273	417	388	568	575	1266	1313	1709	2658	2860	3849	3877							
27	20	11	16	27	64	114	119	160	174	265	247	361	366	805	835	1087	1691	1819	2448	2466							
	15	15	21	36	84	150	156	210	228	347	324	473	479	1054	1093	1423	2214	2382	3205	3229							
	3.5	21	29	50	117	210	218	293	319	486	453	662	671	1476	1530	1991	3098	3333	4486	4519							

DOCTOR WATER CAPACITY TABLE

- It is recommended to keep valve outlet velocity below 30,000 ft./min.
- Capacities based on maximum Cv.



