

PRECISION INSTRUMENT COMPANY

“SE-115D” SERIES GAUGES

These 4 1/2” gauges have been designed and built primarily for the Industrial Market. They are well suited for all applications where bronze tube and socket are suitable for use. Some typical applications are; AIR, WATER, GAS, OIL and STEAM

(* A pig tail / si phon sho uld always be used when putt ing any gauge into steam service)

STANDARD FEATURES

- Epoxy Coated Black Steel Case
(Epoxy Coated For Rust And Corrosion Resistance)
- Plastic Lens (To Resist Breakag e)
- ANSI B40.1 Grade A Accuracy
(1 % Of Full Scale Over Middle Ha lf Of Range
2 % Of Full Scale Over f^t & Last Quarter Of Range)
- Single Scale PSI Only D ial
With L arge Easy To Read Numbers
- Removable Back Fl ange
(For More Diversity From Stock)



PART NUMBER 4 1/2”	RANGE	MAJOR INC	MINOR INC
SE-115D- 454A	30” HG VAC	5”hg	2”hg
SE-115D- 454C C	30/ 0/30	5 psi	1 psi
SE-115D- 454C	0/3 0	5 psi	1 psi
SE-115D- 454D	0/6 0	10 psi	1 psi
SE-115D- 454 E	0/1 00	10 psi	1 psi
SE-115D- 454 F	0/1 60	20 psi	2 psi
SE-115D- 454G	0/2 00	20 psi	2 psi
SE-115D- 454H	0/3 00	50 psi	5 psi
SE-115D- 454K	0/6 00	100 PSI	10 P SI

Note: Al l T ypic al Accessory Type Items Such As Gauge Cock’s, Pi gtail /Siphones’s, Snubber s, Needle Val ves Or Diaphragm Seals Can Be Provided Wit h Gauges Upon Request.

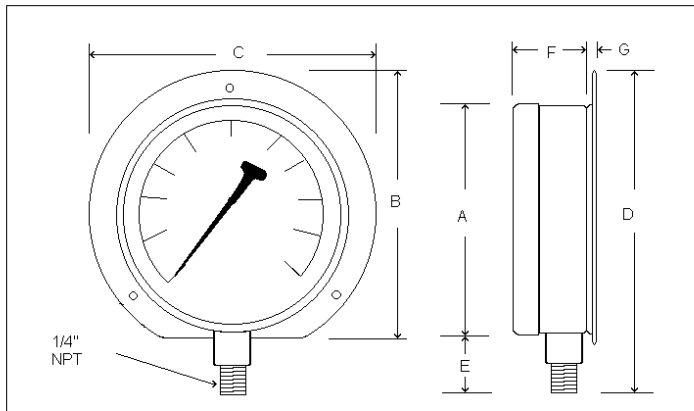

	4 1/2” Dial Size	
	In.	MM
A	4.94”	125
B	5.36”	136
C	5.90”	150
D	6.45”	164
E	1.06”	27
F	1.30”	33
G	.24”	6