

## SPECIFICATIONS

### GENERAL SPECIFICATIONS

The backflow preventer shall be a Double Check Detector Assembly consisting of two (2) independently acting, spring loaded check valves with inlet and outlet resilient-seated gate valves and a by-pass assembly. The by-pass assembly consists of a water meter and an approved double check valve assembly with shut-off valves and test cocks.

The backflow preventer shall be suitable for **supply pressure up to 175 psig and water temperatures from 33 to 140°F.**

The backflow preventer shall be designed to meet the requirements of the following standards: **ASSE 1048, UL, FM, and USC's FCCC&HR.**

The Double Check Detector Assembly shall prevent backflow from a cross-connection of non-potable (non-hazardous) water into the safe drinking water system; and at the same time, it shall detect leakage or unauthorized use of water downstream of the assembly.

### CONBRACO SPECIFICATIONS

The **mainline** unit shall consist of two (2) independent, spring loaded, swing type check valve modules set in an epoxy-coated (FDA approved) ductile iron body with inlet and outlet resilient-seated gate valves, and four (4) test cocks. The seat of each check valve shall be replaceable. The loading of each swing check assembly shall be accomplished by a stainless steel compression spring in a self-contained spring assembly. The cover shall serve to secure the check assembly and as an access for easy repair and maintenance without removing the assembly from the line. Check assemblies and covers shall be interchangeable.

The **by-pass** assembly shall consist of a water meter, an approved double check valve (DC) assembly with (2) shut-off ball valves and four (4) test cocks. The by-pass DC shall have replaceable modular check valve inserts.

All parts of the Double Check Detector Assembly shall be made of corrosion resistant materials.

The backflow preventer shall be suitable for **supply pressure up to 175 psi and water temperatures from 33 to 140°F.**

The assembly shall be designed to meet the requirements of the following standards: **ASSE 1048, UL, FM, and USC's FCCC&HR.**

The manufacturing facility shall be **ISO 9001 REGISTERED.**

The backflow preventer shall be Apollo Valves brand manufactured by **CONBRACO INDUSTRIES, INC.**

## DOUBLE CHECK DETECTOR ASSEMBLY

Sizes 8"-10"



## FEATURES

- Corrosion Resistant
- Replaceable Discs
- Low Head Loss
- Economical
- Short Lay Length
- Light Weight
- Designed For Easy Maintenance
- Interchangeable Check Valve Assemblies
- Maximum Working Pressure 175 psi
- Operating Temperature Range 33-140°F
- U.S. Patent #6,343,618

## APPROVALS

The Series DCDA is approved under ASSE 1048, UL Classified, FM, and USC's FCCC&HR (Horizontal & Vertical Flow-Up).



UL and FM approved backflow preventers must include OS&Y gate valves.

# FLOW CURVES

## MODEL DCDA (4S-600 SERIES)

(●) Rated flow as determined by ASSE design performance standards.

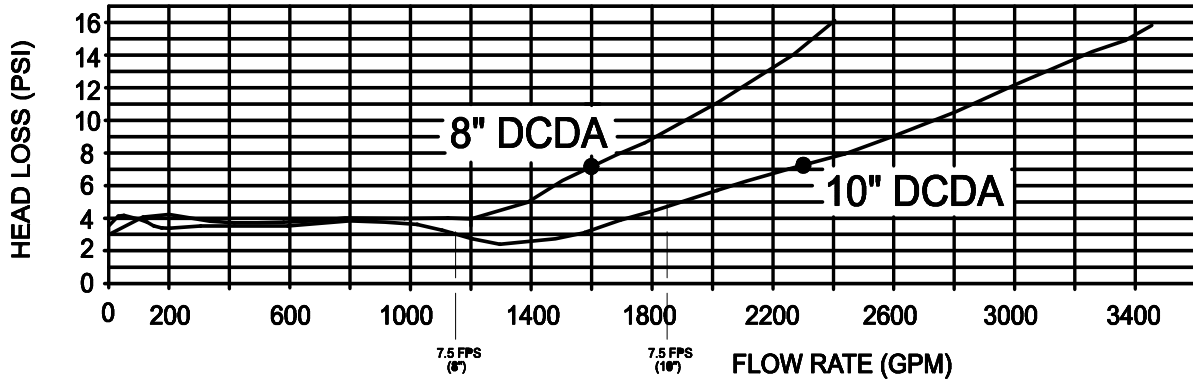

Curves as Recorded at Underwriters Laboratory (Horizontal Position)

## DIMENSIONS (in.) – WEIGHTS (lbs.)

Size	8"	10"
A	50 ¼	55 ¾
B	27	29 ½
C (OS&Y OPEN)	38	46
D	6 ¾	8
E	10 ¾	10 ¾
F	45 ¼	51 ¾
G	34 ¾	39 ½
H	10 ⅛	11 ½
Test Cocks (Mainline)	¾ NPT	¾ NPT
Test Cocks (Bypass)	¼ NPT	¼ NPT
Net Wt. (Less Gate Valves)	440	490
Net Wt. (w/OS&Y Valves)	940	1340
Net Wt. (w/Elbows & OS&Y Valves)	1169	1714
Net Wt. (w/Post Indicator)	920	1277
Shpg. Wt. (Less Gate Valves)	530	585
Shpg. Wt. (w/OS&Y Valves)	1046	1440
Shpg. Wt. (w/Elbows & OS&Y Valves)	1275	1814
Shpg. Wt. (w/Post Indicator)	1026	1377

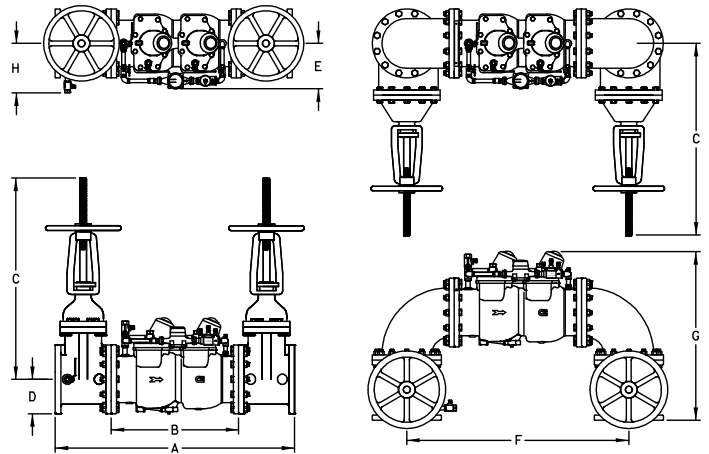

## MATERIALS

Body & Covers	Epoxy Coated (FDA-Approved) Ductile Iron (mainline)
Bypass Valve	Bronze
Springs	Stainless Steel
Seats	Bronze
C.V. Discs	EPDM
Fasteners	Stainless Steel

## ORDERING NUMBERS

### 4S-60X-XXX

Size  
E – 8"  
G – 10"

U – U Flow

Meter Options  
C – Cubic Feet  
E – Gallons  
G – Less Meter

#### Gate Valve Options

- 1 - Less gate valves
- 3 - With OS&Y gate valves
- 6 - With OS&Y Inlet x NRS w/Post Plate & Nut Outlet
- 7 - With OS&Y Flanged Inlet by Grooved Outlet
- 8 - With Grooved x Grooved OS&Y gate valves

## BACKFLOW PRODUCTS DIVISION