

# "Apollo" Valves

BFSS4S10  
SPEC 4S-100

Model DC

## SPECIFICATIONS

### GENERAL SPECIFICATIONS

The backflow preventer shall be a Double Check Valve type including four (4) resilient-seated test cocks and two (2) resilient-seated gate valves.

The two (2) check valves shall be independently acting and internally loaded. Each check valve shall maintain a minimum of 1 psig in the normal direction of flow, under static conditions.

The backflow preventer shall meet the requirements of the following standards: ASSE 1015, AWWA C-510, IAPMO, CSA B64.5, UL and FM Classified, and USC's FCCC & HR.

### APOLLO SPECIFICATIONS

A Double Check Valve backflow preventer shall prevent backflow by either backpressure or back-siphonage from a cross-connection between potable water lines and substances that are objectionable, but not a health hazard.

It shall consist of two (2) independent, spring loaded, swing type check valves set in an epoxy-coated (FDA approved) ductile iron body. The assembly shall have four (4) quarter-turn, full-port, resilient-seated, ball type test cocks and two (2) resilient-wedge gate valves.

All parts shall be made of corrosion resistant materials.

**The seat of each check valve shall be replaceable.**

The loading of each poppet assembly shall be accomplished by a stainless steel compression spring retained in a thermoplastic holder and self contained as an assembly and as an access for easy repair and maintenance without removing the assembly from the line. Check assemblies, and covers shall be interchangeable.

The backflow preventer shall be suitable for **supply pressure up to 175 psig and water temperatures from 33 to 140°F.**

The assembly shall be listed or approved under the following standards: ASSE 1015, AWWA C-510, IAPMO, CSA B64.5, UL and FM Classified, and USC's FCCC & HR.

The manufacturing facility shall be **ISO 9001 REGISTERED.**

The backflow preventer shall be manufactured by **CONBRACO INDUSTRIES, INC.**

## Double Check Valve Assembly

Sizes 2-1/2" - 3" - 4" - 6"

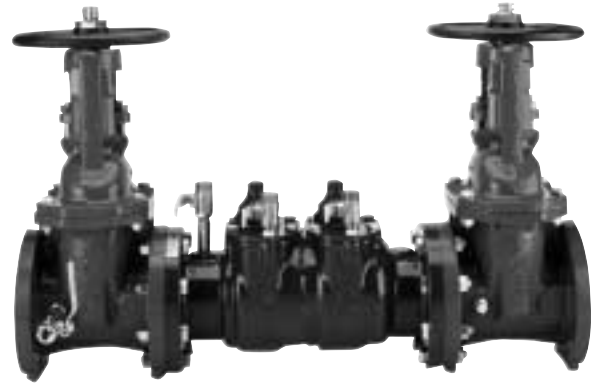

## FEATURES

- Patent #5,711,341
- Corrosion resistant
- Replaceable discs
- Low head loss
- Economical
- Short lay length
- Lightweight
- Designed for easy maintenance
- Interchangeable check valve assemblies
- Maximum working pressure: 175 psi
- Temperature range: 33°F to 140°F

## APPROVALS

The Model DC is approved under ASSE 1015, AWWA C-510, IAPMO, CSA B64.5, UL Classified, FM, and USC's FCCC & HR (Horizontal and Vertical-Up flow).



UL, FM approved backflow preventers must include OS&Y gate valves.

BFSS4S10  
SPEC 4S-100

# FLOW CURVES

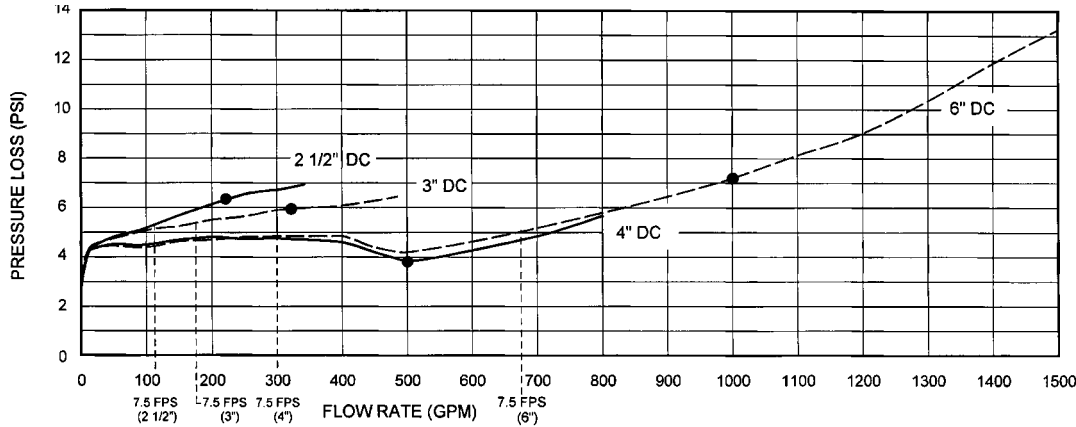

(•) Rated flow as determined by USC's FCCC & HR and ASSE design performance standards.

## DIMENSIONS (in.) – WEIGHTS (lbs.)

Size	2-1/2"	3"	4"	6"
A	32-1/4	33-1/4	34-3/4	39-1/4
B	17	17	16-1/2	18
C NRS	14-7/8	16-1/8	19-1/4	24-1/2
C OS&Y (Open)	19-7/8	22-5/8	27-1/4	35-5/8
D NRS	11-3/8	12-3/8	14-3/4	19
D OS&Y (Open)	17	19	22-3/4	30-1/8
E	9-5/8	10-3/8	11-7/8	14-5/8
F	7	7-1/2	9	11
G	34-5/8	38-1/8	39-5/8	46-1/8
H	19-7/8	20-7/8	22-7/8	25-7/8
Net Wt. (Less Gate Valves)	58	60	68	80
Net Wt. (With NRS Valves)	153	186	254	376
Net Wt. (With OS&Y Valves)	164	194	266	392
Net Wt. (With NRS Valves & Elbows)	189	237	339	511
Net Wt. (With OS&Y Valves & Elbows)	200	245	351	527
Net Wt. (With Ball Valves)	126	136	184	388
Net Wt. (With Post Indicator)	188	214	281	404
Shpg. Wt. (Less Gate Valves)	122	124	132	178
Shpg. Wt. (With NRS Valves)	221	254	324	484
Shpg. Wt. (With OS&Y Valves)	231	261	338	502
Shpg. Wt. (With NRS Valves & Elbows)	257	305	409	619
Shpg. Wt. (With OS&Y Valves & Elbows)	267	312	423	637
Shpg. Wt. (With Ball Valves)	193	203	254	498
Shpg. Wt. (With Post Indicator)	255	281	353	514

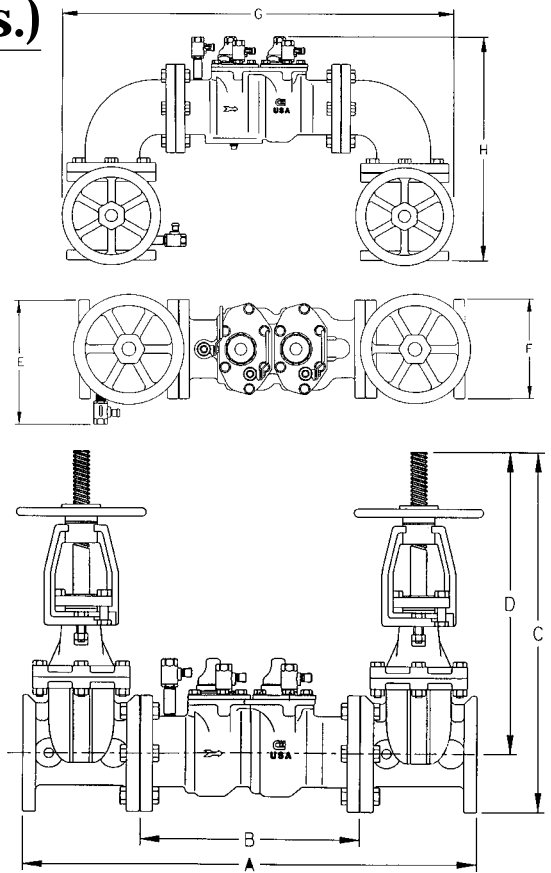

Note: Dimensions shown are nominal. Allowances must be made for manufacturing tolerances.

## MATERIALS

- Body - Epoxy coated (FDA approved) Ductile iron
- Covers - Epoxy coated steel
- Springs - Stainless steel
- Seats - Glass filled Noryl®
- C.V. Discs - EPDM
- Fasteners - Stainless steel

## ORDERING NUMBER

- 4 S - 1 X X - 0 X - U**
- 4 - Size
  - S - 1 - w/Y-strainer (shipped loose)
  - X - 1 - less gate valves
  - X - 2 - w/NRS gate valves
  - X - 3 - w/OS&Y gate valves
  - X - 5 - w/Epoxy coated ball valves
  - X - 6 - w/OS&Y gate valve on inlet, NRS gate valve w/post plate and nut on outlet
  - X - 7 - w/Flanged Inlet x Grooved Outlet
  - X - 8 - w/Grooved x Grooved OS&Y gate valves
  - U - w/Elbows

## BACKFLOW PRODUCTS DIVISION

Conbraco Industries, Inc. P.O. Box 247 Matthews, N.C. 28106 (704) 841-6000 FAX (704) 841-6020-USA-

PRINTED IN USA  
BFSS4S10

<http://www.conbraco.com>

COPYRIGHT © 2004 CONBRACO INDUSTRIES, INC

PP 5M 6/04