

Saturn® 90-100 Series

Bronze Uni-Body Saturn® Ball Valve

Threaded, 300 psig WOG, Cold Non-Shock. 150 psig Saturated Steam.

Federal Specification: WW-V-35C, Type: II, Composition: BZ, Style: 3.

MSS SP-110; Ball Valves Threaded, Socket-Welding, Solder Joint, Grooved and Flared Ends.

FEATURES

- UL Listed at 300 psig for fuel, inert gas and flammable liquids
- Valves with tee handles UL listed
- RPTFE seats and seals
- Blow-out-proof stem design
- Adjustable packing gland
- One piece bronze body
- Chromium plated ball
- Compact

UL LISTINGS



- Guide YRPV: Gas shutoff valve for use with natural and manufactured gases.
- Guide YQNZ: Compressed gas shutoff valve for use with air, inert gases, hydrogen, oxygen and common refrigerants except ammonia.
- Guide YRBX: Flammable liquid shutoff valve.

STANDARD MATERIAL LIST

1. Lever and grip	Steel, zinc plated w/vinyl	6. Retainer	B16
2. Stem packing	RPTFE	7. Gland nut	B16
3. Stem bearing	RPTFE	8. Stem	B16
4. Ball	B16, chrome plated	9. Lever nut (Screw 1/2")	Steel, zinc plated
5. Seat (2)	RPTFE	10. Body	B584-C84400

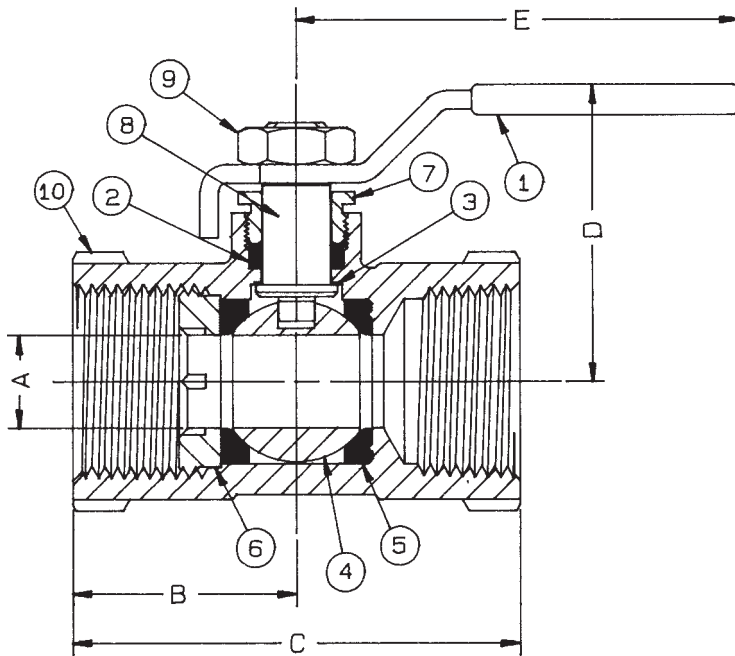

OPTIONS AVAILABLE:

(SUFFIX)	OPTION	SIZES
-05-	Plain Ball	1/2" to 2"
-07-	Steel Tee Handle	1/2" to 2"

BRONZE UNI-BODY SATURN® BALL VALVE

NUMBER	SIZE	A	B	C	D	E	Wt.
90-103-01	1/2"	.38	1.14	2.15	1.64	3.87	.53
90-104-01	3/4"	.50	1.36	2.61	1.78	3.87	.82
90-105-01	1"	.63	1.50	2.90	2.14	4.78	1.25
90-106-01	1-1/4"	.81	1.79	3.50	2.31	4.78	1.98
90-107-01	1-1/2"	1.00	1.96	3.79	2.87	5.43	2.99
90-108-01	2"	1.25	2.29	4.42	3.09	5.43	4.64