



# 89-100 Series

## Carbon Steel Ball Valve

NPT Threaded, 1/4" to 1" 2000 psig WOG, 1-1/4" to 2" 1500 psig WOG, 2-1/2" to 3" 1000 psig WOG. (See referenced P/T chart)

Cold Non-Shock. 150 psig Saturated Steam. Vacuum Service to 29 inches Hg.

Federal Specification: WW-V-35C, Type: II, Composition: CS, Style: 3.

MSS SP-110; Ball Valves Threaded, Socket-Welding, Solder Joint, Grooved and Flared Ends.

### FEATURES

- Investment cast components
- RPTFE seats and stuffing box ring
- Mounting pad for easy actuator mounting
- (-24) Certified to API 607, 4th, Edition, Class 600 burn
- Blow-out-proof stem design
- Adjustable packing gland
- Nitride corrosion protection

### STANDARD MATERIAL LIST

1. Lever and grip	Steel, zinc plated w/vinyl	9. Lever nut	Steel, zinc plated
2. Stem packing	RPTFE	10. Body seal	PTFE (1-1/4" to 3")
3. Stem bearing	RPTFE	11. Body	A216-WCB
4. Ball	A108-CS chrome plated		
5. Seat (2)	RPTFE		
6. Retainer	A108 CS (1/4" to 1")		
	A216-WCB (1-1/4" to 3")		
7. Gland nut	A108-CS		
8. Stem	A108-CS		

### VARIATIONS AVAILABLE:

89-140 Series (316 SS Ball & Stem)

### OPTIONS AVAILABLE:

(SUFFIX)	OPTION	SIZES
-02-	Stem Grounded	1/4" to 3"
-03-	1-1/4" CS Stem Extension	1/4" to 3"
-04-	2-1/4" CS Stem Extension	1/4" to 3"
-07-	Steel Tee Handle	1/4" to 2"
-08-	90° Reversed Stem	1/4" to 3"
-10-	SS Lever & Nut	1/4" to 3"
-14-	Side Vented Ball (Uni-Directional)	1/4" to 3"
-15-	Wheel Handle, Steel	1/4" to 2"
-16-	Chain Lever - Vertical	3/4" to 2"
-18-	Plain Yellow Grip	1/4" to 3"
-19-	Lock Plate	1/4" to 2"
-24-	Graphite Packing	1/4" to 3"
-27-	SS Latch-Lock Lever & Nut	1/4" to 3"
-30-	Cam-Lock and Grounded	1/4" to 2"
-32-	SS Tee Handle & Nut	1/4" to 2"
-35-	VTPE Trim	1/4" to 3"
-39-	SS Hi-Rise Locking Wheel Handle, SS Nut	1/4" to 2"
-40-	Cyl-Loc and Grounded	1/4" to 2"
-44-	Seal Welded	1/4" to 2"
-45-	Less Lever & Nut	1/4" to 3"
-46-	Latch Lock Lever - Lock in Closed Position Only	1/4" to 3"
-47-	SS Oval Latch-Lock Handle & Nut	1/4" to 1"
-48-	SS Oval Handle (No Latch) & Nut	1/4" to 2"
-50-	2-1/4" CS Locking Stem Extension	1/4" to 3"
-56-	Multifill Seats & Packing	1/4" to 3"
-58-	Chain Lever - Horizontal	3/4" to 2"
-60-	Static Grounded Ball & Stem	1/4" to 3"
-64-	250# Steam Trim	1/4" to 3"
-P01-	BSPP (Parallel) Thread Connection	1/4" to 3"
-T01-	BSPT (Tapered) Thread Connection	1/4" to 3"

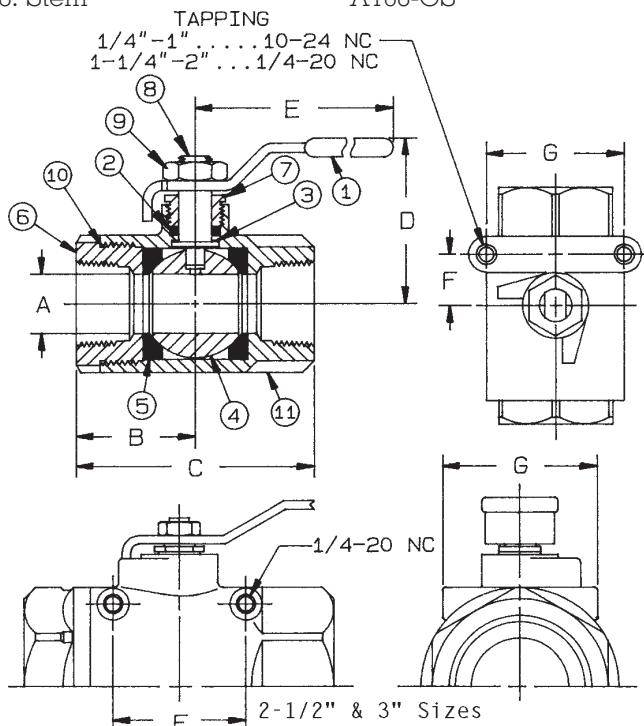

CARBON STEEL BALL VALVE

NUMBER	SIZE	A	B	C	D	E	F	G	Wt.
89-101-01	1/4"	.37	1.03	2.06	1.75	3.87	.50	1.12	.58
89-102-01	3/8"	.37	1.03	2.06	1.75	3.87	.50	1.12	.54
89-103-01	1/2"	.50	1.12	2.25	1.81	3.87	.50	1.12	.63
89-104-01	3/4"	.68	1.50	3.00	2.12	4.87	.87	1.37	1.27
89-105-01	1"	.87	1.68	3.37	2.25	4.87	.87	1.37	1.63
89-106-01	1-1/4"	1.00	2.00	4.00	2.62	5.50	.93	1.50	3.06
89-107-01	1-1/2"	1.25	2.18	4.37	3.05	8.00	.93	1.50	3.98
89-108-01	2"	1.50	2.75	5.50	3.24	8.00	.93	1.50	5.99
89-109-01	2-1/2"	2.50	3.37	6.75	4.05	8.00	2.75	3.37	15.57
89-100-01	3"	2.50	3.37	6.75	4.12	8.00	2.75	3.37	16.79

**For Pressure/Temperature Ratings,  
Refer to Page M-12, Graph No. 13  
(1/4" to 1")  
Refer to Page M-11, Graph No. 11  
(1-1/4" to 2")  
Refer to Page M-10, Graph No. 7  
(2-1/2" to 3")**