



88A-900 Series

Carbon Steel ANSI Class 300 Flanged Full Port Ball Valve - 1/2" through 1"

STANDARDS COMPLIANCE

Refer to page D-A

MATERIALS OF CONSTRUCTION

Description (1/2" & 3/4" Valves)	Material
1. Body	ASTM A216 WCB
2. Retainer	ASTM A108 Type 1215
3. Ball	ASTM A108 Type 1215
4. Stem	ASTM A108 Type 1215
5. Packing Gland	ASTM A108 Type 1215
6. Stem Seals	PTFE
7. Seats	RPTFE
8. Stem Nut	300 Series Stainless Steel
9. Lever	300 Series Stainless Steel w/Vinyl Grip
10. Stem Bearing	RPTFE
11. Stop	300 Series Stainless Steel
12. Body Seal	RPTFE
13. Lock Washer	300 Series Stainless Steel
14. Grounding Spring	ASTM A313 Stainless Steel
15. Grounding Spring	ASTM A313 Stainless Steel

Description (1" Valves)	Material
1. Body	ASTM A216 WCB
2. Retainer	ASTM A108 Type 1215
3. Ball	ASTM A108 Type 1215 Chrome Plated
4. Stem	ASTM A108 Type 1215
5. Packing Gland	ASTM A108 Type 1215
6. Stem Seals	PTFE
7. Seats	RPTFE
8. Gland Screws	ASTM A193 B7
9. Gland Plate	302 or 304 SS
10. Stem Nut	316 SS
11. Lever	ASTM A366 Steel with Vinyl Grip
12. Stem Bearing	RPTFE
13. Stop	ASTM A108 Type 1215
14. Stop Screw	SAE J429 Grade 2
15. Lock Plate	ASTM A366 Steel
16. Body Seal	RPTFE
17. Lockwasher	302 or 304 SS
18. Grounding Spring	SS

STANDARD FEATURES

Refer to page D-A

VARIATIONS AVAILABLE:

88A-940 Series (316 SS Ball & Stem)

88A-930 Series (Ni-Cu Ball & Stem)

OPTIONS AVAILABLE:

(SUFFIX)	OPTION
-01-	Standard
-10-	SS Lever and Nut
-14-	Side Vented Ball (Uni-Directional)
-15-	Wheel Handle, Steel
-21-	UHMWPE Seats
-24-	Fire Safe (Graphite Packing and Seal)
-35-	PTFE Seats and Seals
-38-	PEEK Seats and Graphite Packing
-49-	Assembled Dry
-60-	Grounded Ball and Stem
-65-	MPTFE Seats and Graphite Packing
-67-	Cleaned For Industrial Gases
-69-	Drilled and Tapped Purge Port with Plug
-70-	4" Extended Bonnet
-73-	316 SS Spiral Wound Gaskets w/PTFE Filler
-74-	316 SS Spiral Wound Gaskets w/Graphite Filler
-76-	Live Loaded 87A/88A Series (Lever)
-80-	Multi-Seal (Super TFE) 87A/88A Series

For Pressure/Temperature Ratings, Refer to Page M-9, Graph No. 5

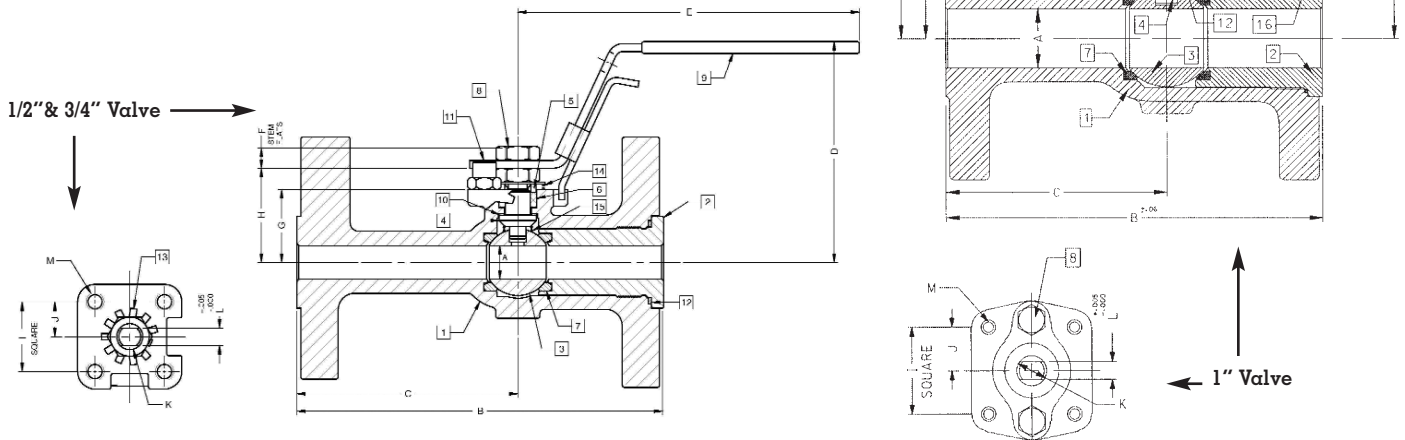

NUMBER	SIZE	A	B	C	D	E	F	G	H	I	J	K	L	M	WT.
88A-903-01	1/2"	0.50	5.50	3.31	3.31	5.11	0.30	1.09	1.38	1.000	0.500	0.375	0.245	10-24	7.0
88A-904-01	3/4"	0.75	6.00	3.56	3.89	5.53	0.36	1.65	1.99	1.392	0.696	0.500	0.287	1/4-20	9.0
88A-905-01	1"	1.00	6.50	3.82	4.62	6.53	0.47	1.62	2.15	1.392	0.696	0.500	0.287	1/4-20	10.5



88A-900 Series

Carbon Steel ANSI Class 300 Flanged Full Port Ball Valve - 1-1/2" through 2-1/2"

STANDARDS COMPLIANCE

Refer to page D-A

STANDARD FEATURES

Refer to page D-A

MATERIALS OF CONSTRUCTION

Description	Material
1. Body	ASTM A216 WCB
2. Retainer	ASTM A216 WCB
3. Ball	ASTM A216 WCB or A216 WCB Chrome Plated
4. Stem	ASTM A108 Type 1215
5. Packing Gland	ASTM A108 Type 1215
6. Stem Seals	PTFE
7. Seats	RPTFE
8. Gland Screws	ASTM A193 B7
9. Gland Plate	302 & 304 SS
10. Stem Nut	ASTM A194 Grade 8I
11. Lever	ASTM A366 Steel with Vinyl Grip
12. Stem Bearing	RPTFE
13. Stop	ASTM A108 Type 1215
14. Stop Screw	SAE J429 Grade 2
15. Lock Plate	ASTM A366 Steel
16. Body Seal	RPTFE
17. Grounding Spring	SS
18. Body Joint Stud	ASTM A193 Grade B7
19. Body Joint Nut	ASTM A194 Grade 2H
20. Lockwasher	302 or 304 SS

VARIATIONS AVAILABLE:

- 88A-940 Series (316 SS Ball & Stem)
- 88A-930 Series (Ni-Cu Ball & Stem)

OPTIONS AVAILABLE:

(SUFFIX)	OPTION
-01-	Standard
-14-	Side Vented Ball (Uni-Directional)
-15-	Wheel Handle, Steel
-21-	UHMWPE Seats
-24-	Fire Safe (Graphite Packing and Seal)
-35-	PTFE Seats and Seals
-38-	PEEK Seats and Graphite Packing
-49-	Assembled Dry
-59-	SS External Trim
-60-	Grounded Ball and Stem
-65-	MPTFE Seats and Graphite Packing
-67-	Cleaned For Industrial Gases
-69-	Drilled and Tapped Purge Ports with Plugs
-70-	4" Extended Bonnet
-73-	316 SS Spiral Wound Gaskets w/PTFE Filler
-74-	316 SS Spiral Wound Gaskets w/Graphite Filler
-76-	Live Loaded 87A/88A Series (Lever)
-80-	Multi-Seal (Super TFE) 87A/88A Series
-MG-	Gear Operator with Standard Handwheel
-MH-	Gear Operator with Standard Handwheel & Locking Device
-MJ-	Gear Operator with Oversize Handwheel
-MK-	Gear Operator with Oversize Handwheel & Locking Device

For Pressure/Temperature Ratings, Refer to Page M-9, Graph No. 5

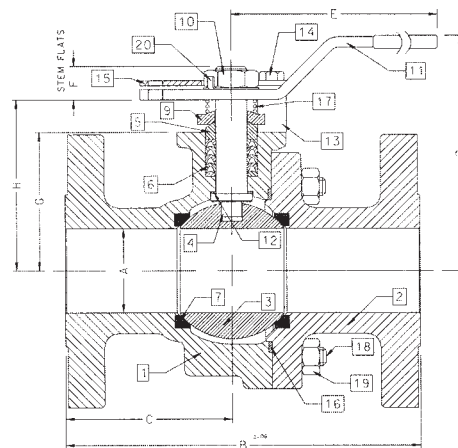
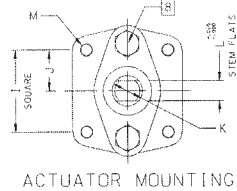

NUMBER	SIZE	A	B	C	D	E	F	G	H	I	J	K	L	M	WT.
88A-907-01	1-1/2"	1.50	7.50	3.50	4.62	6.65	0.72	2.41	3.09	1.949	0.974	0.625	0.412	5/16-18	21.0
88A-908-01	2"	2.00	8.50	4.00	5.61	8.41	0.80	3.31	4.08	1.949	0.974	0.750	0.477	5/16-18	37.0
88A-909-01	2-1/2"	2.50	9.50	4.44	6.24	8.41	0.80	3.94	4.71	1.949	0.974	0.750	0.477	5/16-18	57.0



88A-900 Series

Carbon Steel ANSI Class 300 Flanged Full Port Ball Valve - 3" through 6"

STANDARDS COMPLIANCE

Refer to page D-A

STANDARD FEATURES

Refer to page D-A

MATERIALS OF CONSTRUCTION

Description	Material
1. Body	ASTM A216 WCB
2. Retainer	ASTM A216 WCB
3. Ball	ASTM A216 WCB or A216 WCB Chrome Plated
4. Stem	ASTM A108 Type 1215
5. Packing Gland	ASTM A108 Type 1215
6. Stem Seals	PTFE
7. Seats	RPTFE
8. Gland Screws	ASTM A193 B7
9. Gland Plate	316 SS
10. Adapter Screw	316 SS
11. Handle Adapter	ASTM A366 Steel with Vinyl Grip
12. Stem Bearing	RPTFE
13. Stop	ASTM A108 Type 1215
14. Stop Screw	SAE J429 Grade 2
15. Lock Plate	ASTM A366 Steel
16. Body Seal	RPTFE
17. Grounding Spring	SS
18. Body Joint Stud	ASTM A193 Grade B7
19. Body Joint Nut	ASTM A194 Grade 2H
20. Pipe Handle	Galvanized Steel (not shown)

VARIATIONS AVAILABLE:

88A-940 Series (316 SS Ball & Stem)

88A-930 Series (Ni-Cu Ball & Stem)

OPTIONS AVAILABLE:

(SUFFIX)	OPTION
-01-	Standard
-14-	Side Vented Ball (Uni-Directional)
-21-	UHMWPE Seats
-24-	Fire Safe (Graphite Packing and Seal)
-35-	PTFE Seats and Seals
-38-	PEEK Seats and Graphite Packing
-49-	Assembled Dry
-59-	SS External Trim
-60-	Grounded Ball and Stem
-65-	MPTFE Seats and Graphite Packing
-67-	Cleaned For Industrial Gases
-69-	Drilled and Tapped Purge Ports with Plugs
-70-	4" Extended Bonnet
-73-	316 SS Spiral Wound Gaskets w/PTFE Filler
-74-	316 SS Spiral Wound Gaskets w/Graphite Filler
-76-	Live Loaded 87A/88A Series (Lever)
-80-	Multi-Seal (Super TFE) 87A/88A Series
-MG-	Gear Operator with Standard Handwheel
-MH-	Gear Operator with Standard Handwheel & Locking Device
-MJ-	Gear Operator with Oversize Handwheel
-MK-	Gear Operator with Oversize Handwheel & Locking Device

**For Pressure/Temperature Ratings,
Refer to Page M-9, Graph No. 5**

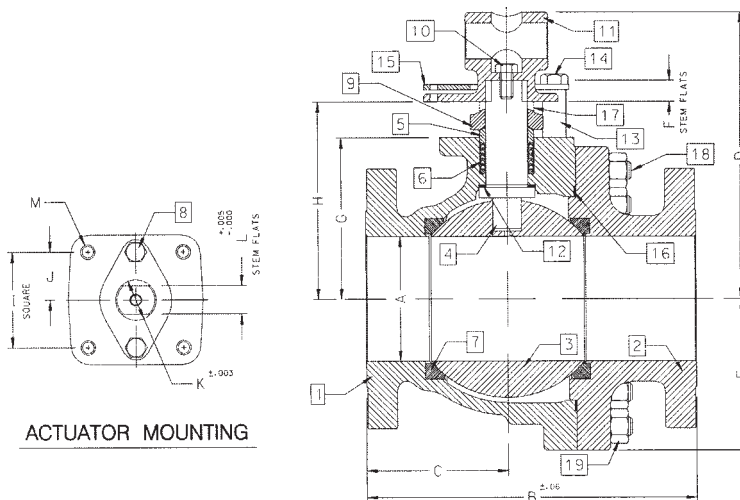

NUMBER	SIZE	A	B	C	D	E	F	G	H	I	J	K	L	M	WT.
88A-900-01	3"	3.00	11.12	5.24	8.80	4.06	0.50	4.75	5.95	2.840	1.420	1.250	0.725	3/8-16	78.0
88A-90A-01	4"	4.00	12.00	5.44	9.99	5.25	0.50	5.94	7.13	2.840	1.420	1.250	0.725	3/8-16	133.0
88A-90C-01	6"	6.00	15.88	6.82	13.73	7.30	1.00	7.75	9.48	4.596	2.296	2.000	1.375	3/4-10	329.0



88A-900 Series

Carbon Steel ANSI Class 300 Flanged Full Port Ball Valve - 8" through 12"

STANDARDS COMPLIANCE

Refer to page D-A

STANDARD FEATURES

Refer to page D-A

MATERIALS OF CONSTRUCTION

Description	Material
1. Body	ASTM A216 WCB
2. Retainer	ASTM A216 WCB
3. Ball	ASTM A108 Type 1215 or A216 WCB
4. Stem	ASTM A108 Type 1215
5. Packing Gland	ASTM A108 Type 1215
6. Stem Seals	PTFE
7. Seats	RPTFE
8. Gland Screws	ASTM A193 B7
9. Gland Plate	316 SS
10. Stem Bearing	RPTFE
11. Body Seal	RPTFE
12. Body Joint Stud	ASTM A193 Grade B7
13. Body Joint Nut	ASTM A194 Grade 2H

VARIATIONS AVAILABLE:

- 88A-930 Series (Ni-Cu Ball & Stem)
- 88A-940 Series (316 SS Ball & Stem)

OPTIONS AVAILABLE:

(SUFFIX)	OPTION
-01-	Standard
-14-	Side Vented Ball (Uni-Directional)
-21-	UHMWPE Seats
-24-	Fire Safe (Graphite Packing and Seal)
-35-	PTFE Seats and Seals
-49-	Assembled Dry
-60-	Grounded Ball and Stem
-65-	MPTFE Seats and Graphite Packing
-67-	Cleaned for Industrial Gas - CS Valves
-69-	Drilled and Tapped Purge Ports with Plugs
-70-	Extended Bonnet (8" Only)
-76-	Live Loaded 87A/88A Series (Lever)
-80-	Multi-Seal (Super TFE) 87A/88A Series
-MG-	Gear Operator with Standard Handwheel
-MH-	Gear Operator with Standard Handwheel & Locking Device
-MJ-	Gear Operator with Oversize Handwheel
-MK-	Gear Operator with Oversize Handwheel & Locking Device

For Pressure/Temperature Ratings, Refer to Page M-9, Graph No. 5

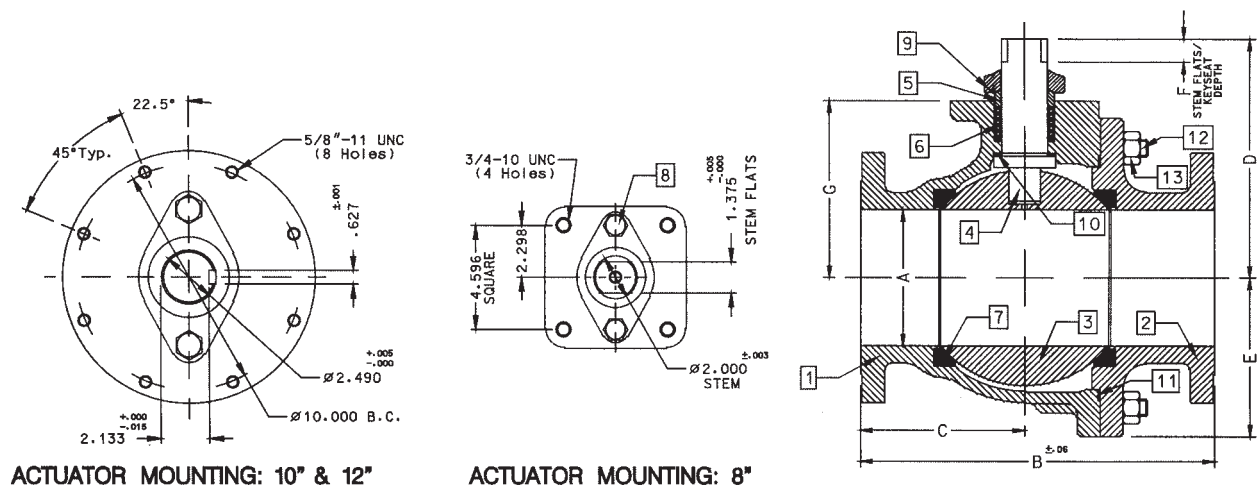

NUMBER	SIZE	A	B	C	D	E	F	G
88A-90E-01	8"	8.00	19.75	9.38	12.83	9.56	1.00	10.22
88A-90G-01	10"	10.00	22.38	10.95	18.57	11.33	2.31	12.80
88A-90H-01	12"	12.00	25.50	12.84	20.31	13.40	2.31	14.92



88B-100 Series

Carbon Steel ANSI Class 150 Flanged Std. Port Ball Valve - 3"

STANDARDS COMPLIANCE

Refer to page D-A

STANDARD FEATURES

Refer to page D-A

MATERIALS OF CONSTRUCTION

Description	Material
1. Body	ASTM A216-WCB
2. Retainer	ASTM A108 Type 1215
3. Ball	ASTM A108 Type 1215 Chrome Plated
4. Stem	ASTM A108 Type 1215 Chrome Plated
5. Packing Gland	ASTM A108 Type 1215
6. Stem Seals	PTFE
7. Seats	RPTFE
8. Gland Screws	ASTM A193 B7
9. Gland Plate	316 SS
10. Stem Nut	18-8 SS
11. Lever	316 SS with Vinyl Grip
12. Stem Bearing	RPTFE
13. Stop	ASTM A108 Type 1215
14. Stop Screw	SAE J429 Grade 2
15. Lock Plate	ASTM A366 Steel
16. Body Seal	RPTFE
17. Grounding Spring	SS
18. Lockwasher	302 or 304 SS

VARIATIONS AVAILABLE:

88B-130 Series (Ni-Cu Ball & Stem)

88B-140 Series (316 SS Ball & Stem)

OPTIONS AVAILABLE:

(SUFFIX)	OPTION
-14-	Side Vented Ball (Uni-Directional)
-21-	UHMWPE Seats
-24-	Fire Safe (Graphite Packing and Seal)
-35-	PTFE Seats and Seals
-38-	PEEK Seats and Graphite Packing (3" Only)
-49-	Assembled Dry
-57-	Oxygen Cleaned
-60-	Grounded Ball and Stem
-65-	MPTFE Seats and Graphite Packing
-69-	Drilled and Tapped Purge Ports with Plugs
-70-	Extended Bonnet
-76-	Live Loaded 87A/88A Series (Lever)
-80-	Multi-Seal (Super TFE) 87A/88A Series
-MG-	Gear Operator with Standard Handwheel
-MH-	Gear Operator with Standard Handwheel & Locking Device
-MJ-	Gear Operator with Oversize Handwheel
-MK-	Gear Operator with Oversize Handwheel & Locking Device

**For Pressure/Temperature Ratings,
Refer to Page M-7, Graph No. 1**

