



86-900 Series

Stainless Steel 3-Piece High Pressure Full Port Butt-Weld Ball Valve

Schedule 10 Butt-Weld, 1/2" to 1" 1500 psig WOG, 1-1/2" & 2" 1250 psig WOG, Cold Non-Shock. 150 psig Saturated Steam.

Vacuum Service to 29 inches Hg.

Federal Specification: WW-V-35C, Type: II, Composition: SS, Style: 1.

MSS SP-110; Ball Valves Threaded, Socket-Welding, Solder Joint, Grooved and Flared Ends.

MSS SP-72; Ball Valves with Flanged or Buttweld Ends for General Service

FEATURES

- Adjustable packing gland
- In-line repairable
- Blow-out-proof stem design
- (-29) Certified to API standard 607, 4th Edition, Class 600 burn
- Meets NACE MR-01-75-97
- Investment Cast Components
- Actuator mounting pad (3/4" to 2")
- RPTFE seats and seals

STANDARD MATERIAL LIST

| | | | |
|--------------------|----------------|-------------------|-----------|
| 1. Lever and grip | 304 SS w/vinyl | 8. Gland nut | A276-316 |
| 2. Stem packing | RPTFE | 9. Stem | A276-316 |
| 3. Stem bearing | RPTFE | 10. Lever nut | 304 SS |
| 4. Ball | A276-316 | 11. Body bolt (4) | 18-8 SS |
| 5. Seat (2) | RPTFE | 12. Hex nut (4) | 18-8 SS |
| 6. End cap (2) | A351-CF3M | 13. Body | A351-CF8M |
| 7. Seat Holder (2) | A276-316 | 14. Body seal (2) | RPTFE |

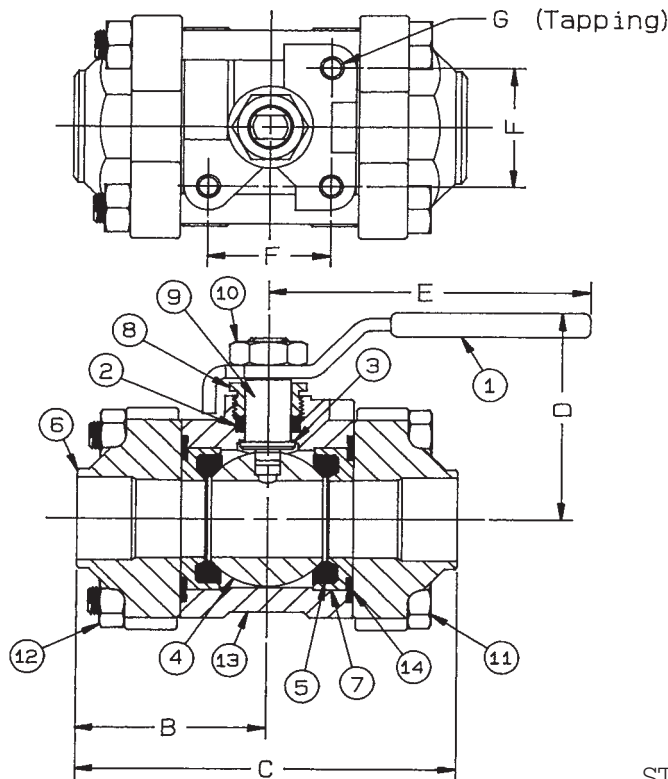

OPTIONS AVAILABLE:

| (SUFFIX) | OPTION | SIZES |
|----------|---|------------|
| -02 | Static Grounded | 1/2" to 2" |
| -03 | 1-1/4" Stem Extension | 1/2" to 2" |
| -04 | 2-1/4" Stem Extension | 1/2" to 2" |
| -07 | Tee Handle | 1/2" to 2" |
| -08 | 90° Reversed Stem | 1/2" to 2" |
| -14 | Vented Ball (see page J-2) | 1/2" to 2" |
| -15 | Round Handle | 1/2" to 2" |
| -16 | Vertical Chain Lever | 1/2" to 2" |
| -18 | Plain Yellow Grip | 1/2" to 2" |
| -27 | Latch Lock Lever | 1/2" to 2" |
| -29 | Firesafe | 1/2" to 2" |
| -32 | SS Tee Handle & Nut | 1/2" to 2" |
| -35 | VTFE Trim | 1/2" to 2" |
| -38 | PEEK Seats & Bearing (Graphite Packing & Seals) | 1/2" to 2" |
| -45 | Less Lever & Nut | 1/2" to 2" |
| -47 | SS Latch-Lock Oval Handle | 1/2" to 2" |
| -48 | SS Oval Handle (No Latch) & Nut | 1/2" to 2" |
| -49 | Assembled Dry | 1/2" to 2" |
| -57 | Oxygen Cleaned | 1/2" to 2" |
| -58 | Chain Lever - Horizontal | 1/2" to 2" |
| -60 | Grounded Ball & Stem | 1/2" to 2" |
| -64 | 250# Steam Trim | 1/2" to 2" |

**For Pressure/Temperature Ratings,
Refer to Page M-11, Graph No. 12**

STAINLESS STEEL 3-PIECE HIGH PRESSURE FULL PORT BUTT-WELD BALL VALVE

| NUMBER | SIZE | A | B | C | D | E | F | G | Wt. |
|------------|--------|------|------|------|------|------|------|---------|-------|
| 86-903-01 | 1/2" | .62 | 1.69 | 3.38 | 2.00 | 4.81 | N/A | N/A | 1.60 |
| 86-904-01A | 3/4" | .81 | 1.93 | 3.87 | 2.18 | 4.81 | 1.25 | 1/4-20 | 2.24 |
| 86-905-01A | 1" | 1.00 | 2.25 | 4.50 | 2.62 | 5.50 | 1.62 | 5/16-18 | 3.32 |
| 86-907-01A | 1-1/2" | 1.50 | 2.62 | 5.25 | 3.35 | 8.00 | 1.62 | 5/16-18 | 8.62 |
| 86-908-01A | 2" | 2.00 | 3.11 | 6.22 | 3.75 | 8.00 | 1.62 | 5/16-18 | 15.60 |