



83R-100 Series

Carbon Steel 3-Piece Full Port Ball Valve With Actuator Ready ISO Mounting Pad 1/4" through 2"

Full Port Threaded, 1/4" to 1" 1000 psig CWP, 1-1/4" to 2" 800 psig CWP, Cold Non-Shock. 150 psig Saturated Steam. Vacuum Service to 29 inches Hg.

Federal Specification: WW-V-35C, Type: II, Composition: CS, Style: 1.

MSS SP-110; Ball Valve Threaded, Socket-Welding, Solder Joint, Grooved and Flared Ends.

FEATURES

- Multi-piece packing set
- ISO 5211 mounting pad
- Blow-out-proof stem design
- In-line repairable
- Adjustable packing gland
- Investment cast components
- RPTFE seats and seals
- Full port configuration

STANDARD MATERIAL LIST

1. Stem	A108-CS	7. Hex nut (4)	Stl-gr. 8-zinc plt
2. Jam nut	Steel, zinc plate	8. Seat (2)	RPTFE
3. Low profile nut	316 SS	9. Ball	A108-CS chrome plate
4. Gland	A276-316	10. Body bolt (4)	Stl-gr. 8-zinc plt
5. Stem bearing	RPTFE	11. Stem packing	MPTFE
6. End cap (2)	A108-CS (1/4" to 1") A216-WCB (1-1/4" to 2")	12. Body	ASTM A216-WCB
		13. Lock tab washer	304 SS
		14. Lever and grip	Stl-zinc plt-w/vinyl

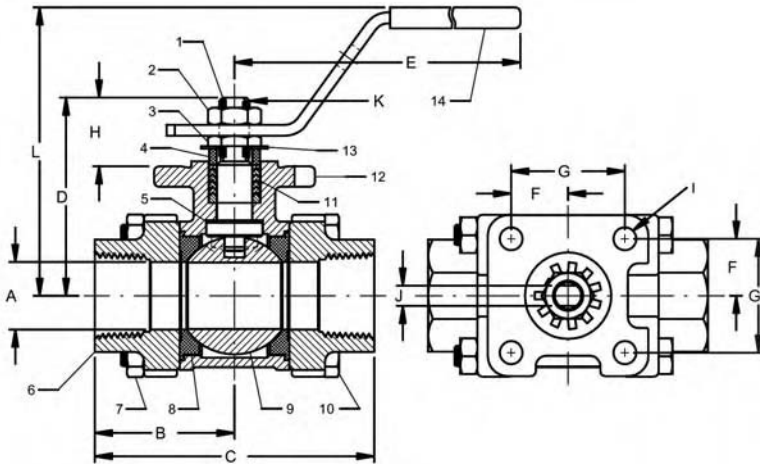

**For Pressure/Temperature Ratings,
Refer to Page M-10, Graph No. 7**

CARBON STEEL 3-PIECE FULL PORT
BALL VALVE WITH ISO MOUNTING PAD

VARIATIONS AVAILABLE:

- 83R-140 Series (316 SS Ball & Stem)
- Meets NACE MR-01-75 (1-1/4" to 2")

OPTIONS AVAILABLE:

(SUFFIX)	OPTION	SIZES
-02-	Static Grounded	1/4" to 2"
-03-	1-1/4" Stem Extension	1/4" to 2"
-04-	2-1/4" Stem Extension	1/4" to 2"
-08-	90° Reversed Stem	1/4" to 2"
-10-	SS Lever & Nut	1/4" to 3"
-14-	Vented Ball	1/4" to 2"
-18-	Plain Yellow Grip	1/4" to 2"
-21-	UHMWPE Seats (Non-PTFE)	1/4" to 2"
-24-	Graphite Stem Packing	1/4" to 2"
-27-	Latch Lock Lever	1/2" to 2"
-35-	VTFE Trim	1/4" to 2"
-36-	SS Round Handle	1/4" to 2"
-39-	SS Hi-Rise Locking Wheel Handle, SS Nut	1/4" to 2"
-56-	Multifill Seats & Graphite Packing	1/4" to 2"
-59-	SS External Trim - 3-pc. Valves	1/4" to 2"
-60-	Grounded Ball & Stem	1/4" to 2"
-63-	NPT x Socket Weld	1/4" to 2"
-66-	NPT x Buttweld	1/4" to 2"
-P01-	BSPP (Parallel) Thread Connection	1/4" to 2"
-T01-	BSPT (Tapered) Thread Connection	1/4" to 2"
-AR-	Less Handle & Stop-Add Belleville Washers	1/4" to 2"
-WB-	With Lever & Belleville Washers	1/4" to 2"

NUMBER	SIZE	A	B	C	D	E	F	G	H	I	J (FLATS)	K (THRDS.) UNF	L
83R-101-01	1/4"	.43	1.40	2.81	2.05	4.18	.59	1.17	.61	.28	.247/.249	3/8-24	3.28
83R-102-01	3/8"	.50	1.40	2.81	2.05	4.18	.59	1.17	.61	.28	.247/.249	3/8-24	3.28
83R-103-01	1/2"	.62	1.40	2.81	2.05	4.18	.59	1.17	.61	.28	.247/.249	3/8-24	3.28
83R-104-01	3/4"	.81	1.71	3.42	2.42	4.93	.70	1.39	.84	.28	.247/.249	3/8-24	3.52
83R-105-01	1"	1.00	1.92	3.85	2.54	4.93	.70	1.39	.84	.28	.247/.249	3/8-24	3.64
83R-106-01	1-1/4"	1.25	2.35	4.70	3.16	8.06	.98	1.95	1.16	.34	.370/.372	5/8-18	4.06
83R-107-01	1-1/2"	1.50	2.59	5.18	3.49	8.06	.98	1.95	1.16	.34	.370/.372	5/8-18	4.38
83R-108-01	2"	2.00	3.01	6.03	3.95	8.06	.98	1.95	1.16	.34	.370/.372	5/8-18	4.85