



76-300 Series

Double Union End Stainless Steel Ball Valve

Threaded, 1/2" to 1" 2000 psig WOG, 1-1/4" to 2" 1500 psig WOG. Cold Non-Shock.
150 psig Saturated Steam, Vacuum Service to 29 inches Hg.

Federal Specification: WW-V-35C, Type: II, Composition: SS, Style: 1.

MSS SP-110; Ball Valves Threaded, Socket-Welding, Solder Joint, Grooved and Flared Ends.

FEATURES

- Heavy duty quarter turn handles
- RPTFE seats and seals
- Blow-out-proof stem design
- Adjustable packing gland

STANDARD MATERIAL LIST

1. Lever and grip	304 SS w/vinyl	9. Lever nut	18-8 SS
2. Stem packing	RPTFE	10. Body	A351-CF8M
3. Stem bearing	RPTFE	11. Tailpiece (2)	A276-316
4. Ball	A276-316	12. Union nut (2)	Nitride A108-CS
5. Seat (2)	RPTFE	13. Seat holder	A276-316
6. Retainer	A276-316	14. Union seal (2)	RPTFE
7. Gland nut	A276-316	15. Retainer seal	RPTFE
8. Stem	A276-316		

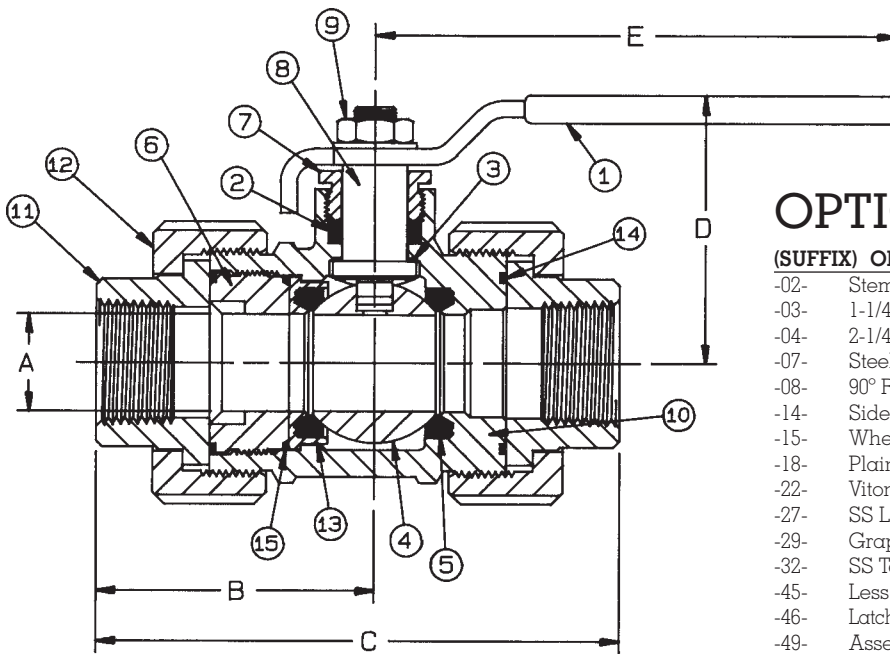

OPTIONS AVAILABLE:

(SUFFIX)	OPTION	SIZES
-02-	Stem Grounded	1/2" to 2"
-03-	1-1/4" CS Stem Extension	1/2" to 1-1/2"
-04-	2-1/4" CS Stem Extension	1/2" to 1-1/2"
-07-	Steel Tee Handle	1/2" to 1-1/2"
-08-	90° Reversed Stem	1/2" to 2"
-14-	Side Vented Ball (Uni-Directional)	1/2" to 2"
-15-	Wheel Handle, Steel	1/2" to 1-1/2"
-18-	Plain Yellow Grip	1/2" to 2"
-22-	Viton Union Seals	1/2" to 2"
-27-	SS Latch-Lock Lever & Nut	1/2" to 1-1/2"
-29-	Graphite Packing & Seals	1/2" to 2"
-32-	SS Tee Handle & Nut	1/2" to 1-1/2"
-45-	Less Lever & Nut	1/2" to 2"
-46-	Latch-Lock Lever - Lock in Closed Position Only	1/2" to 1-1/2"
-49-	Assembled Dry	1/2" to 2"
-57-	Oxygen Cleaned	1/2" to 2"
-60-	Grounded Ball & Stem	1/2" to 2"
-63-	Threaded Socket Weld	1/2" to 2"
-64-	250# Steam Trim	1/2" to 2"
-P01-	BSPP (Parallel) Thread Connection	1/2" to 2"
-T01-	BSPT (Tapered) Thread Connection	1/2" to 2"

STAINLESS STEEL DOUBLE UNION END BALL VALVE

NUMBER	SIZE	A	B	C	D	E	Wt.
76-303-01	1/2"	.62	2.27	4.33	2.12	4.87	2.88
76-304-01	3/4"	.81	2.46	4.51	2.31	4.87	3.81
76-305-01	1"	1.00	2.89	5.45	2.75	5.50	5.98
76-306-01	1-1/4"	1.25	2.88	5.32	2.97	5.50	8.47
76-307-01	1-1/2"	1.50	3.43	6.43	3.39	7.87	12.61
76-308-01	2"	1.75	3.75	6.87	4.12	9.87	16.88

**For Pressure/Temperature Ratings,
Refer to Page M-12, Graph No. 14
(1/2" to 1")
Refer to Page M-11, Graph No.12
(1-1/4" to 2")**