



75-100 Series

Bronze Pad Locking Ball Valve

Threaded, 600 psig WOG, Cold Non-Shock. 150 psig Saturated Steam.

Vacuum Service to 29 inches Hg.

Federal Specification: WW-V-35C, Type: II, Composition: BZ, Style: 3.

MSS SP-110; Ball Valves Threaded, Socket-Welding, Solder Joint, Grooved and Flared Ends.

FEATURES

- Chromium plated ball
- RPTFE seats and stuffing box ring
- May be padlocked in open or closed position with no change of hardware
- Blow-out-proof stem design
- Adjustable packing gland

STANDARD MATERIAL LIST

| | | | |
|-------------------|----------------------------|---------------|--------------------|
| 1. Lever and grip | Steel, zinc plated w/vinyl | 7. Gland nut | B16 |
| 2. Stem packing | RPTFE | 8. Stem | B16 |
| 3. Stem bearing | RPTFE | 9. Lever nut | Steel, zinc plated |
| 4. Ball | B16, chrome plated | 10. Body seal | PTFE (1-1/4" & 2") |
| 5. Seat (2) | RPTFE | 11. Body | B584-C84400 |
| 6. Retainer | B16 (1/4" to 1") | | |
| | B584-C84400 (1-1/4" to 2") | | |

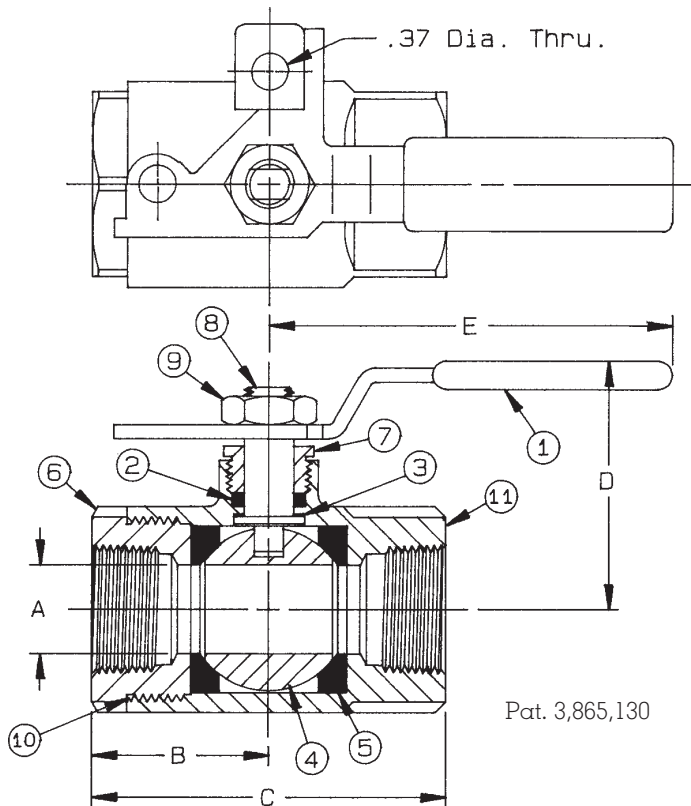

VARIATIONS AVAILABLE:

- 75-140 Series (316 SS Ball & Stem)
- 75-190 Series (Pinned Retainer)

OPTIONS AVAILABLE:

| (SUFFIX) | OPTION | SIZES |
|----------|-------------------------------------|------------|
| -02- | Stem Grounded | 1/4" to 2" |
| -05- | Plain Ball | 1/4" to 2" |
| -08- | 90° Reversed Stem | 1/4" to 2" |
| -10- | SS Lever & Nut | 1/4" to 2" |
| -14- | Side Vented Ball (Uni-Directional) | 1/4" to 2" |
| -17- | Rough Chrome Plated - Bronze Valves | 1/4" to 2" |
| -18- | Plain Yellow Grip | 1/4" to 2" |
| -20- | Slot Vented Ball | 1/4" to 2" |
| -24- | Graphite Packing | 1/4" to 2" |
| -41- | Automatic Drain | 1/4" to 2" |
| | see page J-8 | |
| -49- | Assembled Dry | 1/4" to 2" |
| -57- | Oxygen Cleaned | 1/4" to 2" |
| -60- | Grounded Ball & Stem | 1/4" to 2" |
| -P01- | BSPP (Parallel) Thread Connection | 1/4" to 2" |
| -T01- | BSPT (Tapered) Thread Connection | 1/4" to 2" |

BRONZE PAD LOCKING BALL VALVE

| NUMBER | SIZE | A | B | C | D | E | Wt. |
|-----------|--------|------|------|------|------|------|------|
| 75-101-01 | 1/4" | .43 | 1.12 | 2.25 | 1.81 | 3.00 | .80 |
| 75-102-01 | 3/8" | .50 | 1.12 | 2.25 | 1.81 | 3.00 | .77 |
| 75-103-01 | 1/2" | .50 | 1.12 | 2.25 | 1.81 | 3.00 | .70 |
| 75-104-01 | 3/4" | .87 | 1.68 | 3.37 | 2.25 | 3.87 | 2.03 |
| 75-105-01 | 1" | .87 | 1.68 | 3.37 | 2.25 | 3.87 | 1.83 |
| 75-106-01 | 1-1/4" | 1.00 | 2.00 | 4.00 | 2.62 | 5.50 | 3.48 |
| 75-107-01 | 1-1/2" | 1.25 | 2.18 | 4.37 | 2.87 | 5.50 | 4.23 |
| 75-108-01 | 2" | 1.50 | 2.34 | 4.68 | 3.06 | 5.50 | 5.69 |

**For Pressure/Temperature Ratings,
Refer to Page M-8, Graph No. 4**