



73A-100 Series Carbon Steel Ball Valve

AAR Approved #E999032

Threaded, 1/4" to 1" 2000 psig WOG, 1-1/4" to 2" 1500 psig WOG Cold Non-Shock. 150 psig Saturated Steam.
(See referenced P/T chart)

Vacuum Service to 29 inches Hg.

Federal Specification: WW-V-35C, Type: II, Composition: CS, Style: 3.

MSS SP-110; Ball Valves Threaded, Socket-Welding, Solder Joint, Grooved and Flared Ends.

FEATURES

- RPTFE seats & packing
- Actuator mounting pads
- Forged construction
- Raised handle stops
- Blow-out-proof stem design
- Adjustable packing gland
- Nitride corrosion protection
- (-24) Fire safe to API 607 4th ed. class 600 burn

STANDARD MATERIAL LIST

1. Lever nut	Steel, zinc plated	6. Ball	A108-CS chrome plated
2. Gland nut	A108-CS	7. Seat (2)	RPTFE
3. Stem packing	RPTFE	8. Body	A105
4. Retainer	A108-CS	9. Stem bearing	RPTFE
5. Body seal	RPTFE (1/2" to 2")	10. Stem	A108-CS
		11. Lever/grip	Steel, zinc plated, with vinyl

VARIATIONS AVAILABLE: 73A-140- Series (316 SS Ball & Stem NACE compliant)

OPTIONS AVAILABLE:

(SUFFIX)	OPTION	SIZES
-02-	Stem Grounded	1/4" to 2"
-03-	1-1/4" CS Stem Extension	1/4" to 2"
-04-	2-1/4" CS Stem Extension	1/4" to 2"
-07-	Steel Tee Handle	1/4" to 1-1/2"
-08-	90° Reversed Stem	1/4" to 2"
-10-	SS Lever & Nut	1/4" to 2"
-14-	Vented ball	1/4" to 2"
-15-	Wheel Handle, Steel	1/4" to 1-1/2"
-16-	Chain Lever - Vertical	1/4" to 2"
-21-	UHMWPE Trim (non TFE)	1/4" to 2"
-24-	Graphite Packing	1/4" to 2"
-27-	SS Latch-Lock Lever & Nut	1/4" to 2"
-30-	Cam-Lock & Grounded	1/4" to 2"
-32-	SS Tee Handle & Nut	1/4" to 2"
-35-	VTFE Trim	1/4" to 2"
-39-	SS Hi-Rise Locking Round Handle, SS Nut	1/4" to 2"
-40-	Cyl-Loc & Grounded	1/4" to 2"
-44-	Seal Welded	1/4" to 2"
-45-	Less Lever & Nut	1/4" to 2"
-47-	SS Oval Latch-Lock Handle & Nut	1/4" to 2"
-48-	SS Oval Handle (No Latch) & Nut (No Latch) & Nut	1/4" to 2"
-50-	2-1/4" CS Locking Stem Extension	1/4" to 2"
-52-	Two Tack Welds	1/4" to 2"
-56-	Multi-fill Seats	1/4" to 2"
-58-	Chain Lever - Horizontal	1/4" to 2"
-60-	Static Grounded Ball & Stem	1/4" to 2"
-64-	250# Steam Trim	1/4" to 2"
-67-	Cleaned for Industrial Gas - CS Valves	1/4" to 2"
-P01-	BSP (Parallel) Thread Conn.	1/4" to 2"
-T01-	BSPT (Tapered) Thread Conn.	1/4" to 2"

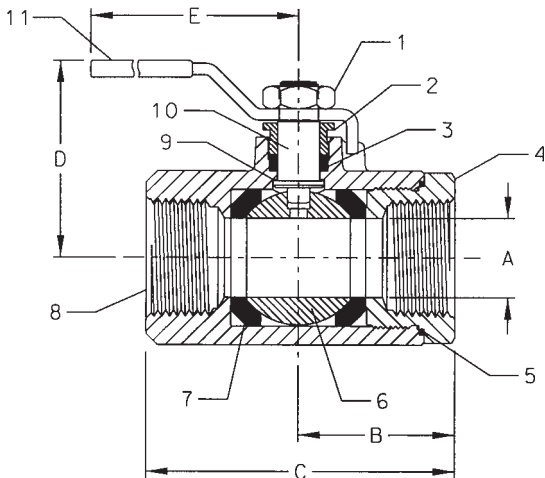

CARBON STEEL BALL VALVE

NUMBER	SIZE	A	B	C	D	E
73A-101-01	1/4"	.37	1.02	2.30	1.72	3.85
73A-102-01	3/8"	.37	1.08	2.37	1.72	3.85
73A-103-01	1/2"	.50	1.18	2.31	1.78	3.85
73A-104-01	3/4"	.68	1.57	3.07	2.07	4.75
73A-105-01	1"	.87	1.73	3.40	2.18	4.75
73A-106-01	1-1/4"	1.00	1.98	3.97	2.72	5.50
73A-107-01	1-1/2"	1.25	2.14	4.32	3.12	7.75
73A-108-01	2"	1.50	2.73	5.44	3.27	7.75

**For Pressure/Temperature Ratings,
Refer to Page M-12, Graph No. 13
(1/4" to 1")
Refer to Page M-11, Graph No. 11
(1-1/4" to 2")**

AAR Approval No. E999032 (when -52 is specified)