



73-400 Series

Carbon Steel Double Union End Socket Weld Ball Valve

Socket Weld End, 3000 psig WOG, Cold Non-Shock, 150 psig Saturated Steam.

Vacuum Service to 29 inches Hg.

Federal Specification: WW-V-35C, Type II, Composition: CS, Style: 1

MSS SP-110; Ball Valves Threaded, Socket-Welding, Solder Joint, Grooved and Flared Ends.

FEATURES

- Heavy duty quarter turn lever
- RPTFE seats and seals
- Steel barstock design
- Easy installation and maintenance
- Blow-out-proof stem design
- Adjustable packing gland
- Chromium plated ball
- Nitride corrosion protection

UL LISTINGS @ 250 PSIG MAX



LISTED

- Guide YRPV: Gas shutoff valve for use with natural and manufactured gases.
- Guide YSDT: LP gas shutoff valve.
- Guide YRBX: Flammable liquid shutoff valve.

Note: Listings apply ONLY to the standard -01 valves.

STANDARD MATERIAL LIST

1. Lever and grip	Steel, zinc plated w/vinyl	9. Lever nut	Steel, zinc plated
2. Stem packing	RPTFE	10. Body	A108-CS
3. Stem bearing	RPTFE	11. Tail piece (2)	A108-1018
4. Ball	A108-CS chrome plated	12. Union nut (2)	A108-CS
5. Seat (2)	RPTFE	13. Seat holder	A108-CS
6. Retainer	A108-CS	14. Union seal (2)	RPTFE
7. Gland nut	A108-CS	15. Retainer seal	RPTFE
8. Stem	A108-CS chrome plated		

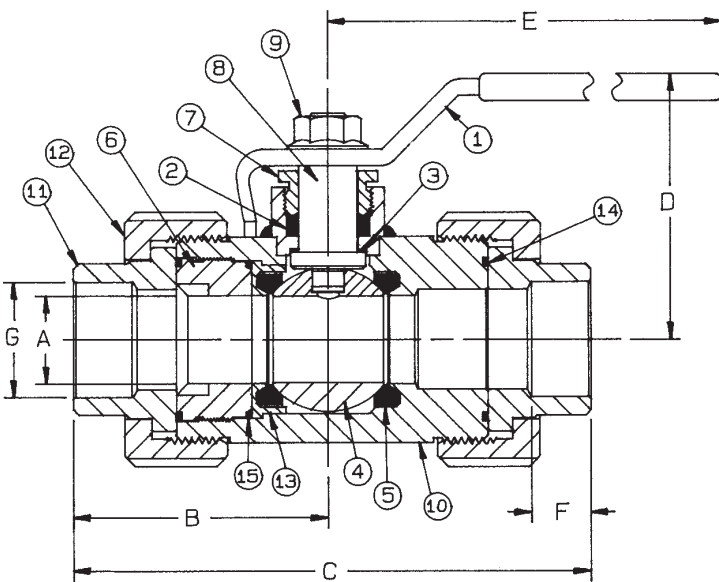

CARBON STEEL DOUBLE UNION END
SOCKET WELD BALL VALVE

NUMBER	SIZE	A	B	C	D	E	F	G	Wt.
73-403-01	1/2"	.62	2.50	5.00	2.50	5.62	.43	.855	3.35
73-404-01	3/4"	.81	2.71	5.31	2.62	5.62	.56	1.065	4.48
73-405-01	1"	1.00	2.93	6.06	3.12	6.62	.68	1.330	7.04
73-406-01	1-1/4"	1.25	2.87	6.12	3.43	8.00	.81	1.675	9.96
73-407-01	1-1/2"	1.50	3.46	7.12	3.56	8.00	.81	1.915	14.83
73-408-01	2"	1.75	3.75	7.50	4.18	9.00	1.06	2.406	20.50

VARIATIONS AVAILABLE:

73-440 Series (316 SS Ball & Stem)

OPTIONS AVAILABLE:

(SUFFIX)	OPTION	SIZES
-02-	Stem Grounded	1/2" to 2"
-07-	Steel Tee Handle	1/2" to 1-1/2"
-08-	90° Reversed Stem	1/2" to 2"
-14-	Side Vented Ball (Uni-Directional)	1/2" to 2"
-15-	Wheel Handle, Steel	1/2" to 1"
-18-	Plain Yellow Grip	1/2" to 2"
-19-	Lock Plate	1/2" to 2"
-21-	UHMWPE Trim (non-PTFE)	1/2" to 2"
-22-	Viton Union Seals	1/2" to 2"
-29-	Graphite Packing & Seals	1/2" to 2"
-45-	Less Lever & Nut	1/2" to 2"
-60-	Grounded Ball & Stem	1/2" to 2"
-64-	250# Steam Trim	1/2" to 2"

**For Pressure/Temperature Ratings,
Refer to Page M-13, Graph No. 15**