



# 70-200 Series Solder End Bronze Ball Valve

Solder End, 600 psig WOG, Cold Non-Shock. 150 psig Saturated Steam. (See referenced P/T charts)  
Vacuum Service to 29 inches Hg.

Federal Specification: WW-V-35C, Type: II, Composition: BZ, Style: 3.

MSS SP-110; Ball Valves, Threaded, Socket-Welding, Solder Joint, Grooved and Flared Ends.

## FEATURES

- Chromium plated ball
- RPTFE seats and stuffing box ring
- Blow-out-proof stem design
- Adjustable packing gland

## STANDARD MATERIAL LIST

1. Lever and grip	Steel, zinc plated w/vinyl	7. Gland nut	B16
2. Stem packing	RPTFE	8. Stem	B16
3. Stem bearing	RPTFE	9. Lever nut	Steel, zinc plated
4. Ball	B16, chrome plated	10. Body seal	PTFE
5. Seat (2)	RPTFE	(1-1/4" to 3")	
6. Retainer	B16 (3/8" to 1")	11. Body	B584-C84400
	B584-C84400 (1-1/4" to 3")		

## VARIATIONS AVAILABLE:

- 70-220 Series (Adjustable Stop Lever)
- 70-240 Series (316 SS Ball & Stem)
- 70-250 Series (Balancing Stop)

## OPTIONS AVAILABLE:

(SUFFIX)	OPTION	SIZES
-02-	Stem Grounded	3/8" to 3"
-03-	1-1/4" CS Stem Extension	3/8" to 3"
-04-	2-1/4" CS Stem Extension	3/8" to 3"
-05-	Plain Ball	3/8" to 3"
-07-	Steel Tee Handle	3/8" to 2"
-08-	90° Reversed Stem	3/8" to 3"
-10-	SS Lever & Nut	3/8" to 3"
-14-	Side Vented Ball (Uni-Directional)	3/8" to 3"
-15-	Wheel Handle, Steel	3/8" to 2"
-16-	Chain Lever - Vertical	3/4" to 2"
-24-	Graphite Packing	3/8" to 3"
-27-	SS Latch-Lock Lever & Nut	3/8" to 3"
-32-	SS Tee Handle & Nut	3/8" to 2"
-35-	VTFE Trim	3/8" to 3"
-39-	SS Hi-Rise Locking Wheel Handle, SS Nut	3/8" to 2"
-45-	Less Lever & Nut	3/8" to 3"
-46-	Latch Lock Lever - Lock in Closed Position Only	3/8" to 3"
-47-	SS Oval Latch-Lock Handle & Nut	3/8" to 1"
-48-	SS Oval Handle (No Latch) & Nut	3/8" to 2"
-49-	Assembled Dry	3/8" to 3"
-50-	2-1/4" CS Locking Stem Extension	3/8" to 3"
-56-	Multifill Seats & Packing	3/8" to 3"
-57-	Oxygen Cleaned	3/8" to 3"
-58-	Chain Lever - Horizontal	3/4" to 2"
-60-	Static Grounded Ball & Stem	3/8" to 3"
-63-	NPT x Solder/Socket Weld	3/8" to 3"

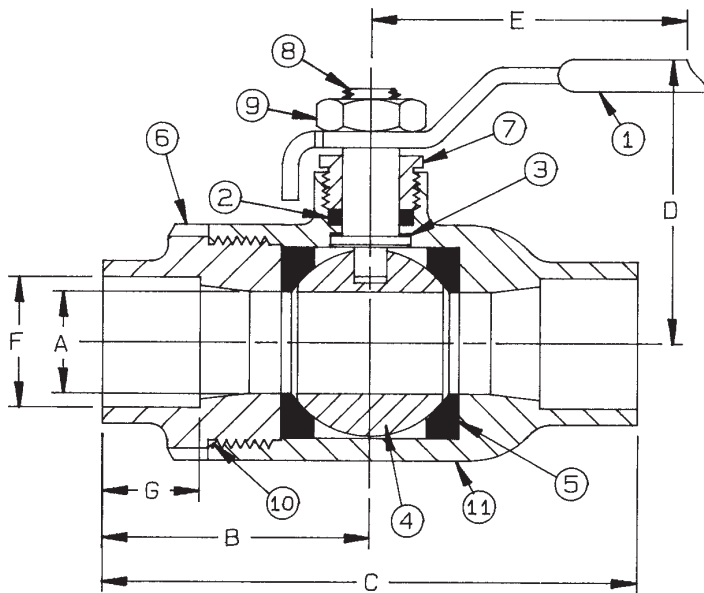

BRONZE BALL VALVE

NUMBER	SIZE	A	B	C	D	E	F	G	Wt.
70-202-01	3/8"	.37	1.28	2.56	1.75	3.87	.505	.37	.63
70-203-01	1/2"	.50	1.43	2.87	1.75	3.87	.630	.50	.71
70-204-01	3/4"	.68	1.93	3.87	2.12	4.87	.880	.75	1.44
70-205-01	1"	.87	2.25	4.50	2.25	4.87	1.130	.90	1.91
70-206-01	1-1/4"	1.00	2.31	4.62	2.62	5.50	1.380	.96	2.95
70-207-01	1-1/2"	1.25	2.62	5.25	3.06	8.00	1.630	1.09	3.99
70-208-01	2"	1.50	3.18	6.37	3.25	8.00	2.130	1.34	5.71
70-209-01A	2-1/2"	2.00	3.74	7.51	3.72	8.00	2.630	1.48	15.53
70-200-01	3"	2.50	4.12	8.25	4.12	8.00	3.130	1.67	16.74

The 70-200 is designed to be soft soldered into lines without disassembly. This allows a tested valve to be installed without disturbing the seats and seals in any way. Soldering temperature not to exceed 500°F.

**For Pressure/Temperature Ratings,  
Refer to Page M-8, Graph No. 4**