



401R-100 Series

Alloy 20 3-Piece Full Port Ball Valve With Actuator Ready ISO Mounting Pad

Full Port Threaded, 1/2" to 1" 1000 psig CWP, 1-1/2" to 3" 800 psig CWP, Cold Non-Shock. 150 psig Saturated Steam Vacuum Service to 29 inches Hg.

Federal Specification: WW-V-35C, Type: II, Composition: SS, Style: 1.

MSS SP-110; Ball Valves, Threaded, Socket-Welding, Solder Joint, Grooved and Flared Ends.

FEATURES

- Multi-piece packing set
- ISO 5211 mounting pad
- Blow-out-proof stem design
- In-line repairable
- Meets NACE MR01-75
- Adjustable packing gland
- Investment cast components
- RPTFE seats and seals
- Full port configuration

STANDARD MATERIAL LIST

1. Stem	B473-N08020	8. Seat (2)	RPTFE
2. Jam nut	SS	9. Ball	B473-N08020
3. Low profile nut	316 SS	10. Body bolt (4)	18-8 SS
4. Gland	A276-316	11. Stem packing	MPTFE
5. Stem bearing	RPTFE	12. Body	ASTM A351-CN7M
6. End cap (2)	ASTM A351-CN7M	13. Lock tab washer	304 SS
7. Hex nut (4)	18-8 SS	14. Lever and grip	304 SS w/vinyl

OPTIONS AVAILABLE:

(SUFFIX)	OPTION	SIZES
-02-	Static Grounded	1/2" to 2"
-03-	1-1/4" Stem Extension	1/2" to 2"
-04-	2-1/4" Stem Extension	1/2" to 2"
-08-	90° Reversed Stem	1/2" to 2"
-14-	Vented Ball	1/2" to 2"
-18-	Plain Yellow Grip	1/2" to 2"
-21-	UHMWPE Seats (Non-PTFE)	1/2" to 2"
-24-	Graphite Stem Packing	1/2" to 2"
-27-	Latch Lock Lever	1/2" to 2"
-35-	VTFE Trim	1/2" to 2"
-36-	SS Hi-Rise Round Handle & Nut	1/2" to 2"
-39-	SS Hi-Rise Locking Wheel Handle, SS Nut	1/2" to 2"
-49-	Assembled Dry	1/2" to 2"
-57-	Oxygen Cleaned	1/2" to 2"
-60-	Grounded Ball & Stem	1/2" to 2"
-63-	NPT x Socket weld	1/2" to 2"
-P01-	BSPP (Parallel) Thread Connection	1/2" to 2"
-T01-	BSPT (Tapered) Thread Connection	1/2" to 2"
-AR-	Less Handle & Stop-Add Belleville Washers	1/2" to 2"
-WB-	With Lever & Belleville Washers	1/2" to 2"

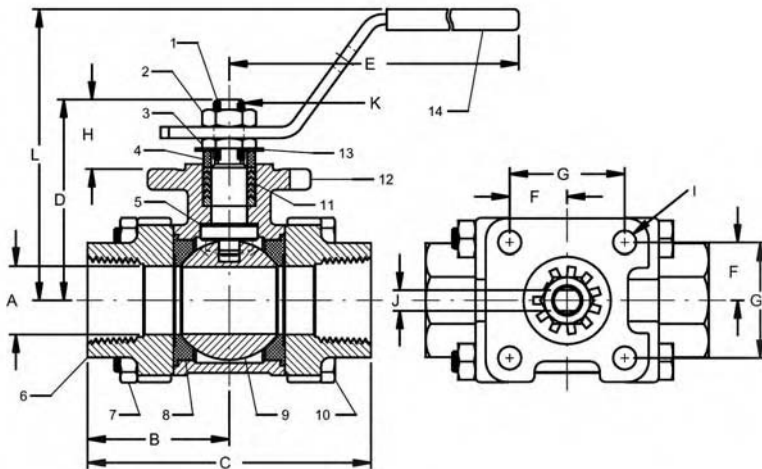

**For Pressure/Temperature Ratings,
Refer to Page M-10, Graph No. 8**

ALLOY 20 3-PC. FULL PORT BV WITH ISO MOUNTING PAD

PART #	SIZE	A	B	C	D	E	F	G	H	I	J (Flats)	K (Thrds.) UNF	L
401R10301	1/2"	.62	1.40	2.81	2.05	4.18	.59	1.17	.61	.28	.247/.249	3/8-24	3.28
401R10401	3/4"	.81	1.71	3.42	2.42	4.93	.70	1.39	.84	.28	.247/.249	3/8-24	3.52
401R10501	1"	1.00	1.92	3.85	2.54	4.93	.70	1.39	.84	.28	.247/.249	3/8-24	3.64
401R10601	1-1/4"	1.25	2.35	4.70	3.16	8.06	.98	1.95	1.16	.34	.370/.372	5/8-18	4.05
401R10701	1-1/2"	1.50	2.59	5.18	3.49	8.06	.98	1.95	1.16	.34	.370/.372	5/8-18	4.38
401R10801	2"	2.00	3.01	6.03	3.95	8.06	.98	1.95	1.16	.34	.370/.372	5/8-18	4.85