



399-100 Series Alloy-20 Ball Valve

Threaded, 1/4" to 1" 2000 psig WOG, 1-1/4" to 2" 1500 psig WOG. Cold Non-Shock. (See referenced P/T chart)
150 psig Saturated Steam. Vacuum Service to 29 inches Hg.
Federal Specification: WW-V-35C, Type: II, Composition: SS, Style: 3.

FEATURES

- Investment cast components
- RPTFE seats and stuffing box ring
- Mounting pad for easy actuator mounting
- (-24) Certified to API standard 607, 4th Edition, Class 600 burn
- Blow-out-proof stem design
- Adjustable packing gland
- Meets NACE MR-01-75

STANDARD MATERIAL LIST

1. Lever and grip	304 SS w/vinyl	7. Gland nut	316 SS
2. Stem packing	RPTFE	8. Stem	B473-N08020
3. Stem bearing	RPTFE	9. Lever nut	304 SS
4. Ball	B463-2OCB-3	10. Body seal	PTFE (1-1/4" to 2")
5. Seat (2)	RPTFE	11. Body	A351-CN7M
6. Retainer	B473-N08020 (1/4" to 1") A351-CN7M (1-1/4" to 2")		

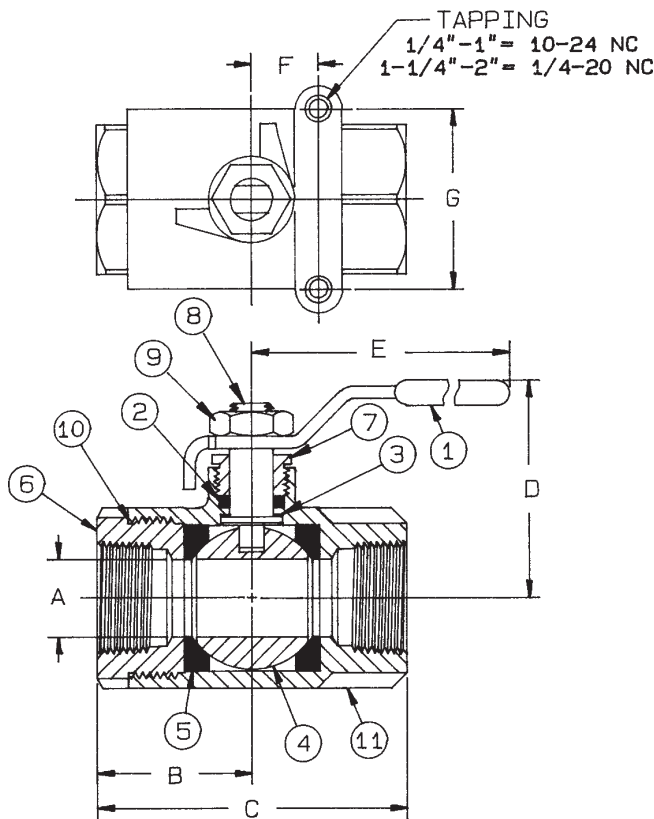

ALLOY-20 BALL VALVE

NUMBER	SIZE	A	B	C	D	E	F	G	Wt.
399-101-01	1/4"	.37	1.03	2.06	1.75	3.87	.50	1.12	.58
399-102-01	3/8"	.37	1.03	2.06	1.75	3.87	.50	1.12	.54
399-103-01	1/2"	.50	1.12	2.25	1.81	3.87	.50	1.12	.63
399-104-01	3/4"	.68	1.50	3.00	2.12	4.87	.87	1.37	1.27
399-105-01	1"	.87	1.68	3.37	2.25	4.87	.87	1.37	1.63
399-106-01	1-1/4"	1.00	2.00	4.00	2.62	5.50	.93	1.50	3.06
399-107-01	1-1/2"	1.25	2.18	4.37	2.87	8.00	.93	1.50	4.04
399-108-01	2"	1.50	2.34	4.68	3.06	8.00	.93	1.50	6.05

OPTIONS AVAILABLE:

(SUFFIX)	OPTION	SIZES
-02-	Stem Grounded	1/4" to 2"
-03-	1-1/4" CS Stem Extension	1/4" to 2"
-04-	2-1/4" CS Stem Extension	1/4" to 2"
-07-	Steel Tee Handle	1/4" to 2"
-08-	90° Reversed Stem	1/4" to 2"
-14-	Side Vented Ball (Uni-Directional)	1/4" to 2"
-15-	Wheel Handle, Steel	1/4" to 2"
-16-	Chain Lever - Vertical	3/4" to 2"
-18-	Plain Yellow Grip	1/4" to 2"
-19-	Lock Plate	1/4" to 2"
-21-	UHMWPE Trim (Non-PTFE)	1/4" to 2"
-24-	Graphite Packing	1/4" to 2"
-27-	SS Latch-Lock Lever & Nut	1/4" to 2"
-28-	Mounting Pad Not Drilled & Tapped	1/4" to 2"
-30-	Cam-Lock and Grounded	1/4" to 2"
-32-	SS Tee Handle & Nut	1/4" to 2"
-35-	VTFE Trim	1/4" to 2"
-40-	Cyl-Loc and Grounded	1/4" to 2"
-45-	Less Lever & Nut	1/4" to 2"
-46-	Latch Lock Lever - Lock in Closed Position Only	1/4" to 2"
-47-	SS Oval Latch-Lock Handle & Nut	1/4" to 1"
-48-	SS Oval Handle (No Latch) & Nut	1/4" to 2"
-49-	Assembled Dry	1/4" to 2"
-50-	2-1/4" CS Locking Stem Extension	1/4" to 2"
-56-	Multifill Seats & Packing	1/4" to 2"
-57-	Oxygen Cleaned	1/4" to 2"
-58-	Chain Lever - Horizontal	3/4" to 2"
-60-	Static Grounded Ball & Stem	1/4" to 2"
-64-	250# Steam Trim	1/4" to 2"
-P01-	BSPP (Parallel) Thread Connection	1/4" to 2"
-T01-	BSPT (Tapered) Thread Connection	1/4" to 2"

**For Pressure/Temperature Ratings,
Refer to Page M-15, Graph No. 20
(1/4" to 1")
Refer to Page M-15, Graph No. 19
(1-1/4" to 2")**