



Section I  
Power Boilers



Section VIII  
Pressure Vessels

# 119 Series Cast Iron Flanged Safety Valves



These flanged, heavy duty and high capacity safety valves are ideal for use on all types of boilers, pressure vessels and pressure piping systems. These ruggedly built valves offer you a cost-saving alternative to conventional steel bodied valves — without compromising quality or performance. These valves feature a top guided design and two control rings to ensure seat tightness, repeatable performance and extended service life. Flow ratings are National Board certified.

ASME Sections I & VIII, for steam, air and gas service  
Set pressures to 250 psig at 450°F max  
Flanged inlet sizes 1 1/2" through 6" ANSI 250 lb.  
Threaded inlet sizes 2" through 3" FNPT

**Applications:** Overpressure protection of steam boilers, deaerators, accumulators, pressure reducing stations and pressure piping systems. Pneumatic conveying equipment, air and gas compressors, receivers and dryers. Per the ASME code, cast iron safety relief valves must not be used for lethal or flammable fluid service.

**Features**

- Metal to metal seating, lapped to optical flatness
- High-capacity semi-nozzle design available in 8 orifice sizes
- **New! Stainless steel wetted trim is now standard\***
- Two control rings assure maximum performance and dependability
- Designed for new installations and replacement of existing valves (high flow rates and face to face dimensions enable direct replacement of most competitive models)
- Designed for ease of service or repair
- Ductile iron caps, forks and levers for added durability
- Registered in all Canadian provinces under CSA B51, CRN OG8547.5C

**Options**

- Drip pan elbows for discharge piping (See pg. 42)

\* Commencing January 2004, subject to depletion of remaining stock of bronze trim.

## 119 Series Model Numbering System

119	K	H	C	A	MAA	0150
Series Number	Orifice Letter	Inlet (in.)	Connection	Service	Special Options	Set Pressure
119 Stainless Steel Wetted Trim	The orifice letter from the Capacity Chart Pg. 39-41	G = 1-1/2 H = 2 J = 2-1/2 K = 3 M = 4 P = 6	A = FNPT X FNPT C = 250# X FNPT D = 250# X 125#	A = Section I Steam K = Section VIII Air L = Section VIII Steam N = Non Code Air P = Non Code Steam	Factory issued letters/numbers (MAA default)	Set pressure psig (4 digits)

**How to select**

- 1 Determine the orifice letter that corresponds to your required flow rate from the capacity charts on pages 39-41.
- 2 Select the inlet x outlet connection options from the list of models available for that orifice from page 38.
- 3 Enter this base model number into the matrix above. Complete by specifying the code, service and set pressure requirements.

**Examples:**

119 KHC A MAA 0150 = 2" "K" 3" ASME Section I steam service valve set at 150 psig, with flanged inlet.

119 QPD L MAA 0025 = 6" "Q" 8" ASME Section VIII steam service valve set at 25 psi, with flanged inlet.

## 119 Series Cast Iron Flanged Safety Valves

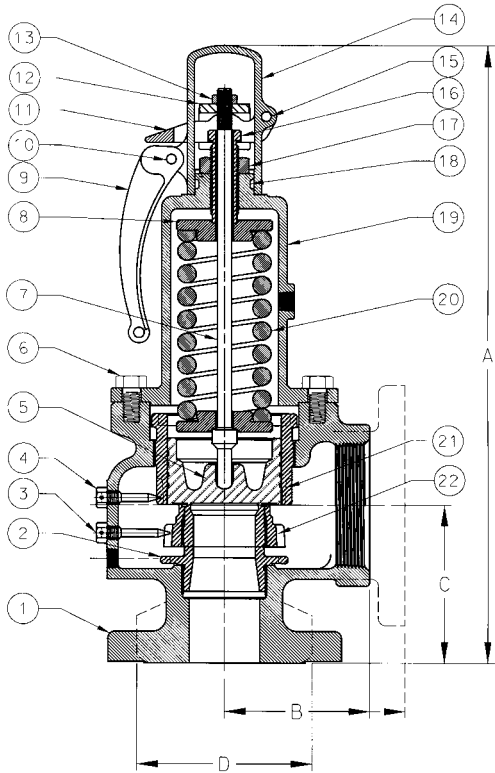

### Materials

Item	Component	Material
1	BODY	GRAY IRON
2	NOZZLE	STAINLESS STEEL
3	NOZZLE RING SCREW	BRASS
4	GUIDE RING SCREW	BRASS
5	DISC	STAINLESS STEEL
6	BONNET BOLT	STEEL (PLATED)
7	STEM	STEEL (PLATED)
8	SPRING WASHER	STEEL (PLATED)
9	TEST LEVER	DUCTILE IRON OR BRONZE
10	CLEVIS PIN	STEEL (PLATED)
11	LIFTING FORK	DUCTILE IRON
12	STEM NUT	STEEL (PLATED)
13	STEM NUT LOCK NUT	STEEL (PLATED)
14	LIFTING CAP	DUCTILE IRON
15	CLEVIS PIN	STEEL (PLATED)
16	ADJUSTING SCREW	BRASS
17	LOCK NUT	STEEL (PLATED)
18	LIFT CAP LOCKSCREW	STEEL (PLATED)
19	BONNET	GRAY IRON
20	SPRING	STEEL (PLATED) OR SS
21	DISC GUIDE	BRASS OR BRONZE
22	NOZZLE RING	BRASS OR BRONZE
-	NAMEPLATE	ALUMINUM
-	SEAL AND WIRE	LEAD/STEEL

### Selection/Dimensions and Weights

Model Number*	Valve Size (in./mm.) Inlet x Outlet	Orifice Size	Dimensions (in./mm.)			Hex Flat D (in./mm)	Weight (lbs./kg.)
			A	B	C		
<b>119 JGC</b>	1-1/2 250# X 2-1/2 FNPT DN40 x DN65	J	15	4	4.31		35
			381	101	109		15.8
<b>119 KHC</b>	2 250# X 3 FNPT DN50 x DN80	K	16	4	4.63		36
			406	101	109		16.3
<b>119 KHA</b>	2 FNPT X 3 FNPT DN50 x DN80	K	16	4	4.63	3.75	37
			406	101	109	95	16.7
<b>119 KJC</b>	2-1/2 250# X 3 FNPT DN65 x DN80	K	16	4	4.63		41
			406	101	109		18.6
<b>119 LJC</b>	2-1/2 250# X 4 FNPT DN65 x DN100	L	22	5.13	5.63		84
			558	130	143		38.1
<b>119 LJA</b>	2-1/2 FNPT X 4 FNPT DN65 x DN100	L	22	5.13	5.63	5.375	81
			558	130	143	136	36.7
<b>119 LKC</b>	3 250# X 4 FNPT DN80 x DN100	L	22	5.13	5.63		85
			558	130	143		38.5
<b>119 MKA</b>	3 FNPT X 4 FNPT DN80 x DN100	M	22	5.13	5.63	5.75	80
			558	130	143	146	36.2
<b>119 MKC</b>	3 250# X 4 FNPT DN80 x DN100	M	22	5.13	5.63		87
			558	130	143		39.4
<b>119 NMD</b>	4 250# X 6 125# DN100 x DN150	N	28	7.25	6.75		210
			711	184	171		95.2
<b>119 PMD</b>	4 250# X 6 125# DN100 x DN150	P	28	7.25	6.75		215
			711	184	171		97.5
<b>119 QPD</b>	6 250# X 8 125# DN150 x DN200	Q	42	10	9.25		530
			1066	254	234		240.4
<b>119 RPD</b>	6 250# X 8 125# DN150 x DN200	R	42	10	9.25		530
			1066	254	234		240.4

# 119 Series

## Cast Iron Flanged Safety Valves



### ASME Section I Steam



POUNDS PER HOUR (KILOGRAMS PER HOUR) SATURATED STEAM AT 3%  
OVERPRESSURE. NATIONAL BOARD CERTIFIED. RATINGS ARE 90% OF ACTUAL.

U.S. Customary Units lbs./hr.									Metric Units kg./hr.								
Orifice Letter	J	K	L	M	N	P	Q	R	Orifice Letter	J	K	L	M	N	P	Q	R
Area (In <sup>2</sup> )	1.358	1.926	2.99	3.774	4.55	6.692	11.593	16.786	Area (Cm <sup>2</sup> )	8.762	12.426	19.287	24.347	29.357	43.174	74.795	108.294
Set Pressure									Set Pressure								
psig									barg								
15	1,947	2,761	4,286	5,410	6,522	9,592	16,617	2,4061	1.1	910	1,290	2,002	2,527	3,048	4,482	7,764	11,242
20	2,254	3,196	4,962	6,263	7,551	11,105	19,238	27,856	1.5	1,071	1,519	2,358	2,976	3,589	5,278	9,144	13,239
25	2,561	3,632	5,638	7,116	8,579	12,618	21,859	31,651	2	1,273	1,806	2,803	3,538	4,266	6,274	10,868	15,736
30	2,868	4,067	6,314	7,969	9,608	14,131	24,480	35,446	2.5	1,475	2,092	3,247	4,099	4,943	7,269	12,593	18,233
35	3,175	4,502	6,990	8,823	10,637	15,644	27,101	39,241	3	1,677	2,379	3,692	4,660	5,619	8,264	14,317	20,729
40	3,482	4,938	7,666	9,676	11,665	17,157	29,722	43,036	3.5	1,879	2,665	4,137	5,222	6,296	9,260	16,041	23,226
45	3,789	5,373	8,342	10,529	12,694	18,670	32,343	46,831	4	2,081	2,952	4,581	5,783	6,973	10,255	17,766	25,723
50	4,096	5,809	9,018	11,382	13,723	20,183	34,964	50,626	4.5	2,283	3,238	5,026	6,344	7,650	11,250	19,490	28,219
55	4,403	6,244	9,694	12,236	14,751	21,696	37,585	54,421	5	2,490	3,531	5,481	6,919	8,343	12,270	21,256	30,776
60	4,710	6,680	10,370	13,089	15,780	23,209	40,206	58,216	5.5	2,698	3,827	5,939	7,497	9,040	13,295	23,032	33,348
65	5,017	7,115	11,046	13,942	16,809	24,722	42,827	62,011	6	2,906	4,122	6,397	8,075	9,737	14,320	24,808	35,919
70	5,330	7,559	11,735	14,812	17,858	26,265	45,501	65,882	6.5	3,114	4,417	6,855	8,653	10,434	15,345	26,584	38,491
75	5,646	8,008	12,432	15,691	18,918	27,823	48,200	69,791	7	3,322	4,712	7,313	9,232	11,131	16,371	28,360	41,062
80	5,962	8,456	13,128	16,570	19,977	29,382	50,900	73,700	7.5	3,530	5,007	7,771	9,810	11,828	17,396	30,136	43,634
85	6,279	8,905	13,824	17,449	21,037	30,940	53,600	77,609	8	3,738	5,302	8,229	10,388	12,526	18,421	31,912	46,205
90	6,595	9,353	14,520	18,328	22,096	32,498	56,299	81,518	8.5	3,947	5,597	8,687	10,966	13,223	19,446	33,689	48,777
95	6,911	9,802	15,217	19,207	23,156	34,057	58,999	85,427	9	4,155	5,892	9,145	11,544	13,920	20,471	35,465	51,349
100	7,227	10,250	15,913	20,085	24,215	35,615	61,698	89,336	9.5	4,363	6,187	9,603	12,122	14,617	21,497	37,241	53,920
105	7,544	10,699	16,609	20,964	25,275	37,173	64,398	93,245	10	4,571	6,482	10,061	12,700	15,314	22,522	39,017	56,492
110	7,860	11,147	17,305	21,843	26,334	38,732	67,098	97,154	10.5	4,779	6,777	10,519	13,279	16,011	23,547	40,793	59,063
115	8,176	11,596	18,002	22,722	27,394	40,290	69,797	101,063	11	4,987	7,072	10,977	13,857	16,708	24,572	42,569	61,635
120	8,492	12,044	18,698	23,601	28,453	41,848	72,497	104,971	11.5	5,195	7,367	11,435	14,435	17,405	25,598	44,345	64,206
125	8,809	12,493	19,394	24,480	29,513	43,407	75,197	108,880	12	5,403	7,662	11,893	15,013	18,102	26,623	46,121	66,778
130	9,125	12,941	20,091	25,358	30,573	44,965	77,896	112,789	12.5	5,611	7,958	12,351	15,591	18,800	27,648	47,897	69,349
135	9,441	13,390	20,787	26,237	31,632	46,524	80,596	116,698	13	5,819	8,253	12,809	16,169	19,497	28,673	49,673	71,921
140	9,757	13,838	21,483	27,116	32,692	48,082	83,295	120,607	13.5	6,027	8,548	13,267	16,747	20,194	29,698	51,449	74,492
145	10,073	14,287	22,179	27,995	33,751	49,640	85,995	124,516	14	6,235	8,843	13,725	17,325	20,891	30,724	53,225	77,064
150	10,390	14,735	22,876	28,874	34,811	51,199	88,695	128,425	15	6,451	9,433	14,641	18,482	22,285	32,774	56,777	82,207
155	10,706	15,184	23,572	29,753	35,870	52,757	91,394	132,334	16	7,068	10,023	15,557	19,638	23,679	34,824	60,330	87,350
160	11,022	15,632	24,268	30,631	36,930	54,315	94,094	136,243	17	7,484	10,613	16,473	20,794	25,073	36,875	63,882	92,493
165	11,338	16,081	24,964	31,510	37,989	55,874	96,794	140,152	Approx 0.1 barg Increments 41.6 59.0 91.6 115.6 139.4 205.0 355.2 514.3								
170	11,655	16,529	25,661	32,389	39,049	57,432	99,493	144,061									
175	11,971	16,978	26,357	33,268	40,108	58,990	102,193	147,969									
180	12,287	17,426	27,053	34,147	41,168	60,549	104,893	151,878									
185	12,603	17,875	27,750	35,026	42,228	62,107	107,592	155,787									
190	12,920	18,323	28,446	35,905	43,287	63,665	110,292	159,696									
195	13,236	18,772	29,142	36,783	44,347	65,224	112,991	163,605									
200	13,552	19,220	29,838	37,662	45,406	66,782	115,691	167,514									
205	13,868	19,669	30,535	38,541	46,466	68,340	118,391	171,423									
210	14,184	20,117	31,231	39,420	47,525	69,899	121,090	175,332									
215	14,501	20,566	31,927	40,299	48,585	71,457	123,790	179,241									
220	14,817	21,014	32,623	41,178	49,644	73,015	126,490	183,150									
225	15,133	21,463	33,320	42,056	50,704	74,574	129,189	187,059									
230	15,449	21,911	34,016	42,935	51,764	76,132	131,889	190,958									
235	15,766	22,360	34,712	43,814	52,823	77,691	134,589	194,876									
240	16,082	22,808	35,409	44,693	53,883	79,249	137,288	198,785									
245	16,398	23,257	36,105	45,572	54,942	80,807	139,988	202,694									
250	16,714	23,705	36,801	46,451	56,002	82,366	142,687	206,603									
Approx. 1 psi Increments	63	90	139	176	212	312	540	782									

# 119 Series

## Cast Iron Flanged Safety Valves

### ASME Section VIII Steam

POUNDS PER HOUR (KILOGRAMS PER HOUR) SATURATED STEAM AT 10%  
OVERPRESSURE. NATIONAL BOARD CERTIFIED. RATINGS ARE 90% OF ACTUAL.



U.S. Customary Units lbs./hr.									Metric Units kg./hr.									
Orifice Letter	J	K	L	M	N	P	Q	R	Orifice Letter	J	K	L	M	N	P	Q	R	
Area (in.)	1.358	1.926	2.99	3.774	4.55	6.692	11.593	16.786	Area (Cm <sup>2</sup> )	8.762	12.426	19.287	24.347	29.357	43.174	74.795	108.294	
Set Pressure									Set Pressure									
psig									barg									
5	1,312	1,860	2,888	3,645	4,395	6,464	11,198	16,213	.34	590	836	1,298	1,639	1,976	2,906	5,034	7,289	
10	1,798	2,550	3,957	4,995	6,023	8,859	15,346	22,220	.69	822	1,165	1,809	2,283	2,753	4,049	7,014	10,155	
15	2,008	2,848	4,421	5,580	6,728	9,895	17,141	24,820	1.1	937	1,329	2,064	2,605	3,141	4,619	8,002	11,586	
20	2,315	3,283	5,097	6,433	7,756	11,408	19,762	28,615	1.5	1,099	1,559	2,419	3,054	3,682	5,415	9,382	13,584	
25	2,622	3,719	5,773	7,287	8,785	12,921	22,383	32,410	2	1,301	1,845	2,864	3,615	4,359	6,411	11,106	16,080	
30	2,929	4,154	6,449	8,140	9,814	14,434	25,004	36,205	2.5	1,520	2,156	3,347	4,225	5,094	7,492	12,979	18,792	
35	3,267	4,633	7,193	9,079	10,945	16,098	27,887	40,379	3	1,743	2,471	3,836	4,842	5,839	8,587	14,876	21,539	
40	3,604	5,112	7,936	10,017	12,077	17,762	30,771	44,554	3.5	1,965	2,787	4,325	5,460	6,583	9,682	16,773	24,285	
45	3,942	5,591	8,680	10,956	13,208	19,426	33,654	48,729	4	2,187	3,102	4,814	6,077	7,328	10,777	18,670	27,031	
50	4,280	6,070	9,423	11,894	14,340	21,091	36,537	52,903	4.5	2,409	3,417	5,303	6,695	8,072	11,872	20,566	29,778	
55	4,618	6,549	10,167	12,833	15,471	22,755	39,420	57,078	5	2,632	3,732	5,793	7,312	8,817	12,967	22,463	32,524	
60	4,955	7,028	10,911	13,771	16,603	24,419	42,303	61,252	5.5	2,854	4,047	6,282	7,929	9,561	14,061	24,360	35,270	
65	5,293	7,507	11,654	14,710	17,735	26,083	45,186	65,427	6	3,076	4,362	6,771	8,547	10,306	15,156	26,257	38,017	
70	5,631	7,986	12,398	15,649	18,866	27,748	48,069	69,601	6.5	3,298	4,677	7,260	9,164	11,050	16,251	28,153	40,763	
75	5,969	8,465	13,141	16,587	19,998	29,412	50,952	73,776	7	3,520	4,992	7,749	9,782	11,795	17,346	30,050	43,509	
80	6,306	8,944	13,885	17,526	21,129	31,076	53,835	77,951	7.5	3,743	5,308	8,238	10,399	12,539	18,441	31,947	46,255	
85	6,644	9,423	14,629	18,464	22,261	32,740	56,719	82,125	8	3,965	5,623	8,727	11,017	13,284	19,536	33,844	49,002	
90	6,982	9,902	15,372	19,403	23,392	34,405	59,602	86,300	8.5	4,187	5,938	9,216	11,634	14,028	20,631	35,741	51,748	
95	7,319	10,381	16,116	20,341	24,524	36,069	62,485	90,474	9	4,409	6,253	9,706	12,251	14,773	21,726	37,637	54,494	
100	7,657	10,860	16,859	21,280	25,655	37,733	65,368	94,649	9.5	4,631	6,568	10,195	12,869	15,517	22,820	39,534	57,241	
105	7,995	11,339	17,603	22,218	26,787	39,397	68,251	98,823	10	4,854	6,883	10,684	13,486	16,262	23,915	41,431	59,987	
110	8,333	11,818	18,346	23,157	27,919	41,062	71,134	102,998	10.5	5,076	7,198	11,173	14,104	17,006	25,010	43,328	62,733	
115	8,670	12,297	19,090	24,096	29,050	42,726	74,017	107,173	11	5,298	7,513	11,662	14,721	17,750	26,105	45,224	65,480	
120	9,008	12,776	19,834	25,034	30,182	44,390	76,900	111,347	11.5	5,520	7,829	12,151	15,338	18,495	27,200	47,121	68,226	
125	9,346	13,255	20,577	25,973	31,313	46,055	79,783	115,522	12	5,742	8,144	12,640	15,956	19,239	28,295	49,018	70,972	
130	9,684	13,734	21,321	26,911	32,445	47,719	82,666	119,696	12.5	5,965	8,459	13,129	16,573	19,984	29,390	50,915	73,718	
135	10,021	14,213	22,064	27,850	33,576	49,383	85,550	123,871	13	6,187	8,774	13,618	17,191	20,728	30,485	52,811	76,465	
140	10,359	14,692	22,808	28,788	34,708	51,047	88,433	128,045	13.5	6,409	9,089	14,108	17,808	21,473	31,580	54,708	79,211	
145	10,697	15,171	23,552	29,727	35,839	52,712	91,316	132,220	14	6,631	9,404	14,597	18,426	22,217	32,674	56,605	81,957	
150	11,034	15,650	24,295	30,666	36,971	54,376	94,199	136,395	15	7,076	10,034	15,575	19,660	23,706	34,864	60,399	87,450	
155	11,372	16,129	25,039	31,604	38,103	56,040	97,082	140,569	16	7,520	10,665	16,553	20,895	25,195	37,054	64,192	92,943	
160	11,710	16,608	25,782	32,543	39,234	57,704	99,965	144,744	17	7,964	11,295	17,531	22,130	26,684	39,244	67,986	98,435	
165	12,048	17,087	26,526	33,481	40,366	59,369	102,848	148,918	Approx. 0.1 barg									
170	12,385	17,566	27,270	34,420	41,497	61,033	105,731	153,093	Increment	44.4	63.0	97.8	123.5	148.9	219.0	379.4	549.3	
175	12,723	18,045	28,013	35,358	42,629	62,697	108,614	157,267										
180	13,061	18,524	28,757	36,297	43,760	64,361	111,497	161,442										
185	13,399	19,003	29,500	37,236	44,892	66,026	114,381	165,617										
190	13,736	19,482	30,244	38,174	46,023	67,690	117,264	169,791										
195	14,074	19,961	30,988	39,113	47,155	69,354	120,147	173,966										
200	14,412	20,440	31,731	40,051	48,287	71,018	123,030	178,140										
205	14,749	20,919	32,475	40,990	49,418	72,683	125,913	182,315										
210	15,087	21,398	33,218	41,928	50,550	74,347	128,796	186,489										
215	15,425	21,876	33,962	42,867	51,681	76,011	131,679	190,664										
220	15,763	22,355	34,706	43,806	52,813	77,675	134,562	194,839										
225	16,100	22,834	35,449	44,744	53,944	79,340	137,445	199,013										
230	16,438	23,313	36,193	45,683	55,076	81,004	140,329	203,188										
235	16,776	23,792	36,936	46,621	56,207	82,668	143,212	207,362										
240	17,113	24,271	37,680	47,560	57,339	84,332	146,095	211,537										
245	17,451	24,750	38,424	48,498	58,471	85,997	148,978	215,711										
250	17,789	25,229	39,167	49,437	59,602	87,661	151,861	219,886										
Approx. 1 psi									Increment	68	96	149	188	226	333	577	835	

# 119 Series

## Cast Iron Flanged Safety Valves

### ASME Section VIII Air



STANDARD CUBIC FEET PER MINUTE (NORMALIZED CUBIC METERS PER HOUR) OF AIR AT 10% OVERPRESSURE. NATIONAL BOARD CERTIFIED. RATINGS ARE 90% OF ACTUAL.



U.S. Customary Units SCFM									Metric Units Nm <sup>3</sup> /hr.								
Orifice Letter	J	K	L	M	N	P	Q	R	Orifice Letter	J	K	L	M	N	P	Q	R
Area (In <sup>2</sup> )	1.358	1.926	2.99	3.774	4.55	6.692	11.593	16.786	Area (Cm <sup>2</sup> )	8.762	12.426	19.287	24.347	29.357	43.174	74.795	108.294
Set Pressure									Set Pressure								
psig									barg								
5	418	592	919	1,160	1,399	2,058	3,565	5,161	0.4	722	1,024	1,589	2,006	2,418	3,557	6,161	8,921
10	583	826	1,282	1,619	1,952	2,870	4,973	7,200	0.8	1,005	1,425	2,212	2,793	3,367	4,952	8,579	12,422
15	715	1,014	1,574	1,986	2,395	3,522	6,101	8,834	1.1	1,182	1,677	2,603	3,286	3,961	5,826	10,093	14,615
20	824	1,169	1,814	2,290	2,761	4,060	7,034	10,185	1.5	1,386	1,996	3,052	3,852	4,644	6,831	11,833	17,134
25	933	1,324	2,055	2,594	3,127	4,599	7,967	11,536	2	1,641	2,327	3,613	4,560	5,498	8,086	14,008	20,283
30	1,043	1,479	2,295	2,897	3,493	5,138	8,900	12,887	2.5	1,918	2,720	4,222	5,329	6,425	9,449	16,370	23,703
35	1,163	1,649	2,560	3,231	3,896	5,730	9,926	14,373	3	2,198	3,117	4,839	6,108	7,364	10,830	18,762	27,166
40	1,283	1,820	2,825	3,566	4,299	6,322	10,953	15,859	3.5	2,478	3,514	5,456	6,887	8,303	12,211	21,154	30,630
45	1,403	1,990	3,089	3,900	4,701	6,915	11,979	17,345	4	2,758	3,912	6,073	7,665	9,241	13,592	23,546	34,094
50	1,523	2,161	3,354	4,234	5,104	7,507	13,005	18,830	4.5	3,038	4,309	6,690	8,444	10,180	14,973	25,938	37,557
55	1,644	2,331	3,619	4,568	5,507	8,099	14,031	20,316	5	3,319	4,707	7,307	9,223	11,119	16,354	28,331	41,021
60	1,764	2,502	3,884	4,902	5,910	8,692	15,057	21,802	5.5	3,599	5,104	7,924	10,002	12,058	17,735	30,723	44,485
65	1,884	2,672	4,148	5,236	6,312	9,284	16,084	23,288	6	3,879	5,502	8,541	10,780	12,997	19,115	33,115	47,948
70	2,004	2,843	4,413	5,570	6,715	9,877	17,110	24,774	6.5	4,159	5,899	9,158	11,559	13,936	20,496	35,507	51,412
75	2,124	3,013	4,678	5,904	7,118	10,469	18,136	26,260	7	4,439	6,296	9,775	12,338	14,875	21,877	37,899	54,876
80	2,245	3,184	4,942	6,238	7,521	11,061	19,162	27,746	7.5	4,720	6,694	10,392	13,116	15,813	23,258	40,291	58,339
85	2,365	3,354	5,207	6,572	7,924	11,654	20,188	29,232	8	5,000	7,091	11,009	13,895	16,752	24,639	42,683	61,803
90	2,485	3,524	5,472	6,906	8,326	12,246	21,215	30,718	8.5	5,280	7,489	11,626	14,674	17,691	26,020	45,076	65,267
95	2,605	3,695	5,736	7,240	8,729	12,838	22,241	32,204	9	5,560	7,886	12,243	15,453	18,630	27,400	47,468	68,730
100	2,726	3,865	6,001	7,574	9,132	13,431	23,267	33,689	9.5	5,841	8,283	12,860	16,231	19,569	28,781	49,860	72,194
105	2,846	4,036	6,266	7,908	9,535	14,023	24,293	35,175	10	6,121	8,681	13,477	17,010	20,508	30,162	52,252	75,658
110	2,966	4,206	6,530	8,243	9,937	14,616	25,320	36,661	10.5	6,401	9,078	14,093	17,789	21,447	31,543	54,644	79,121
115	3,086	4,377	6,795	8,577	10,340	15,208	26,346	38,147	11	6,681	9,476	14,710	18,568	22,385	32,924	57,036	82,585
120	3,206	4,547	7,060	8,911	10,743	15,800	27,372	39,633	11.5	6,961	9,873	15,327	19,346	23,234	34,305	59,428	86,049
125	3,327	4,718	7,324	9,245	11,146	16,393	28,398	41,119	12	7,242	10,271	15,944	20,125	24,263	35,686	61,820	89,512
130	3,447	4,888	7,589	9,579	11,548	16,985	29,424	42,605	12.5	7,522	10,668	16,561	20,904	25,202	37,066	64,213	91,976
135	3,567	5,059	7,854	9,913	11,951	17,577	30,451	44,091	13	7,802	11,065	17,178	21,683	26,141	38,447	66,605	96,440
140	3,687	5,229	8,118	10,247	12,354	18,170	31,477	45,577	13.5	8,082	11,463	17,795	22,461	27,080	39,828	68,997	99,903
145	3,807	5,400	8,383	10,581	12,757	18,762	32,503	47,063	14	8,362	11,860	18,412	23,240	28,019	41,209	71,389	103,367
150	3,928	5,570	8,648	10,915	13,160	19,355	33,529	48,549	15	8,643	12,259	19,064	24,118	29,019	42,719	73,309	105,337
155	4,048	5,741	8,912	11,249	13,562	19,947	34,556	50,034	16	8,923	12,655	19,646	25,098	29,896	43,971	75,173	107,294
160	4,168	5,911	9,177	11,583	13,965	20,539	35,582	51,520	17	9,203	13,051	20,227	26,141	30,916	45,123	77,037	109,251
165	4,288	6,082	9,442	11,917	14,368	21,132	36,608	53,006		9,483	13,450	20,880	26,355	31,774	46,732	80,958	117,222
170	4,408	6,252	9,706	12,251	14,771	21,724	37,634	54,492		10,444	14,245	22,114	27,912	33,652	49,494	85,742	124,149
175	4,529	6,423	9,971	12,586	15,173	22,317	38,660	55,978	Approx. 0.1 barg								
180	4,649	6,593	10,236	12,920	15,576	22,909	39,687	57,464	Increment	56.0	79.5	123.4	155.8	187.8	276.2	478.4	692.7
185	4,769	6,764	10,500	13,254	15,979	23,501	40,713	58,950									
190	4,889	6,934	10,765	13,588	16,382	24,094	41,739	60,436									
195	5,010	7,105	11,030	13,922	16,784	24,686	42,765	61,922									
200	5,130	7,275	11,294	14,256	17,187	25,278	43,791	63,408									
205	5,250	7,446	11,559	14,590	17,590	25,871	44,818	64,893									
210	5,370	7,616	11,824	14,924	17,993	26,463	45,844	66,379									
215	5,490	7,787	12,088	15,258	18,396	27,056	46,870	67,865									
220	5,611	7,957	12,353	15,592	18,798	27,648	47,896	69,351									
225	5,731	8,128	12,618	15,926	19,201	28,240	48,923	70,837									
230	5,851	8,298	12,883	16,260	19,604	28,833	49,949	72,323									
235	5,971	8,469	13,147	16,594	20,007	29,425	50,975	73,809									
240	6,091	8,639	13,412	16,929	20,409	30,017	52,001	75,295									
245	6,212	8,810	13,677	17,263	20,812	30,610	53,027	76,781									
250	6,332	8,980	13,941	17,597	21,215	31,202	54,054	78,267									
Approx. 1 psi																	
Increment	24	34	53	67	81	118	205	297									